

## DUAL-OUTPUT, LOW DROPOUT VOLTAGE REGULATORS WITH INTEGRATED SVS FOR SPLIT VOLTAGE SYSTEMS

### FEATURES

- Dual Output Voltages for Split-Supply Applications
- Independent Enable Functions (See Part Number TPS701xx for Sequenced Outputs)
- Output Current Range of 500mA on Regulator 1 and 250mA on Regulator 2
- Fast Transient Response
- Voltage Options: 3.3V/2.5V, 3.3V/1.8V, 3.3V/1.5V, 3.3V/1.2V, and Dual Adjustable Outputs
- Open Drain Power-On Reset with 120ms Delay
- Open Drain Power Good for Regulator 1 and Regulator 2
- Ultralow 190µA (typ) Quiescent Current
- 1µA Input Current During Standby
- Low Noise: 65µV<sub>RMS</sub> Without Bypass Capacitor
- Quick Output Capacitor Discharge Feature
- One Manual Reset Input
- 2% Accuracy Over Load and Temperature
- Undervoltage Lockout (UVLO) Feature
- 20-Pin PowerPAD™ TSSOP Package
- Thermal Shutdown Protection

### DESCRIPTION

The TPS702xx is a low dropout voltage regulator with integrated SVS (RESET, POR, or power on reset) and power good (PG) functions. These devices are capable of supplying 500mA and 250mA by regulator 1 and regulator 2 respectively. Quiescent current is typically 190µA at full load. Differentiated features, such as accuracy, fast transient response, SVS supervisory circuit (power on reset), manual reset input, and independent enable functions provide a complete system solution.

**PWP PACKAGE  
(TOP VIEW)**

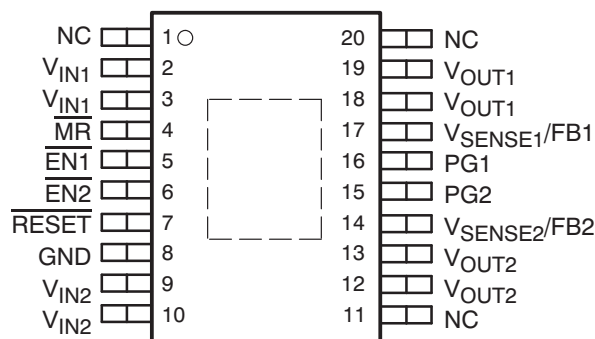

NC = No internal connection

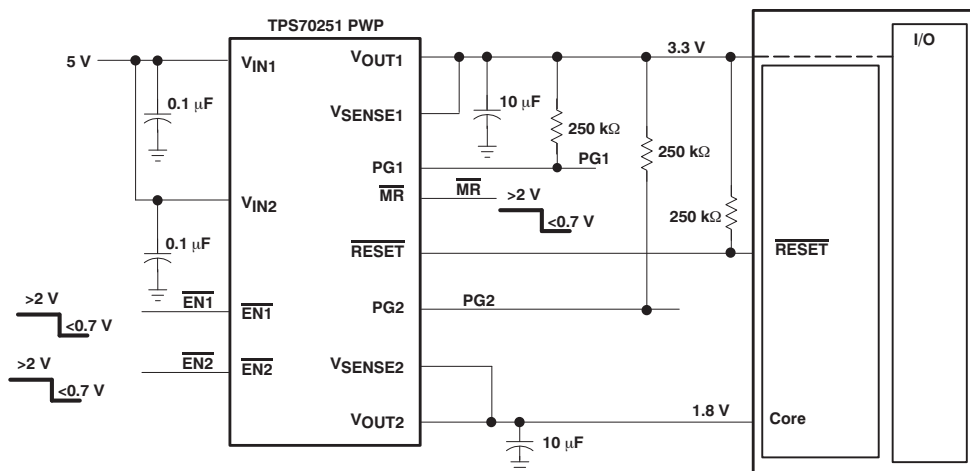

Please be aware that an important notice concerning availability, standard warranty, and use in critical applications of Texas Instruments semiconductor products and disclaimers thereto appears at the end of this data sheet.

PowerPAD is a trademark of Texas Instruments.  
All other trademarks are the property of their respective owners.

The TPS702xx family of voltage regulators offers very low dropout voltage and dual outputs. These devices have extremely low noise output performance without using any added filter bypass capacitors and are designed to have a fast transient response and be stable with 10 $\mu$ F low ESR capacitors.

These devices have fixed 3.3V/2.5V, 3.3V/1.8V, 3.3V/1.5V, 3.3V/1.2V, and adjustable voltage options. Regulator 1 can support up to 500mA, and regulator 2 can support up to 250mA. Separate voltage inputs allow the designer to configure the source power.

Because the PMOS device behaves as a low-value resistor, the dropout voltage is very low (typically 170mV on regulator 1) and is directly proportional to the output current. Additionally, since the PMOS pass element is a voltage-driven device, the quiescent current is very low and independent of output loading (maximum of 230 $\mu$ A over the full range of output current and full range of temperature). This LDO family also features a sleep mode; applying a high signal to  $\overline{\text{EN1}}$  or  $\overline{\text{EN2}}$  (enable) shuts down regulator 1 or regulator 2, respectively. When a high signal is applied to both  $\overline{\text{EN1}}$  and  $\overline{\text{EN2}}$ , both regulators enter sleep mode, thereby reducing the input current to 2 $\mu$ A at  $T_J = +25^\circ\text{C}$ .

For each regulator, there is an internal discharge transistor to discharge the output capacitor when the regulator is turned off (disabled).

The PG1 pin reports the voltage condition at  $V_{\text{OUT1}}$ . The PG1 pin can be used to implement a SVS ( $\overline{\text{RESET}}$ , POR, or power on reset) for the circuitry supplied by regulator 1. The PG2 pin reports the voltage conditions at  $V_{\text{OUT2}}$ . The PG2 pin can be used to implement a SVS (power on reset) for the circuitry supplied by regulator 2.

The TPS702xx features a  $\overline{\text{RESET}}$  (SVS, POR, or power on reset).  $\overline{\text{RESET}}$  output initiates a reset in the event of an undervoltage condition.  $\overline{\text{RESET}}$  also indicates the status of the manual reset pin ( $\overline{\text{MR}}$ ). When  $\overline{\text{MR}}$  is in the logic high state,  $\overline{\text{RESET}}$  goes to a high impedance state after a 120ms delay. To monitor  $V_{\text{OUT1}}$ , the PG1 output pin can be connected to  $\overline{\text{MR}}$ . To monitor  $V_{\text{OUT2}}$ , the PG2 output pin can be connected to  $\overline{\text{MR}}$ .

The device has an undervoltage lockout UVLO circuit that prevents the internal regulators from turning on until  $V_{\text{IN1}}$  reaches 2.5V.



This integrated circuit can be damaged by ESD. Texas Instruments recommends that all integrated circuits be handled with appropriate precautions. Failure to observe proper handling and installation procedures can cause damage.

ESD damage can range from subtle performance degradation to complete device failure. Precision integrated circuits may be more susceptible to damage because very small parametric changes could cause the device not to meet its published specifications.

### ORDERING INFORMATION<sup>(1)</sup>

PRODUCT	VOLTAGE (V) <sup>(2)</sup>		PACKAGE-LEAD (DESIGNATOR)	SPECIFIED TEMPERATURE RANGE (T <sub>J</sub> )	ORDERING NUMBER	TRANSPORT MEDIA, QUANTITY
	V <sub>OUT1</sub>	V <sub>OUT2</sub>				
TPS70202	Adjustable	Adjustable	HTSSOP-20 (PWP)	-40°C to +125°C	TPS70202PWP	Tube, 70
					TPS70202PWPR	Tape and Reel, 2000
TPS70245	3.3V	1.2V	HTSSOP-20 (PWP)	-40°C to +125°C	TPS70245PWP	Tube, 70
					TPS70245PWPR	Tape and Reel, 2000
TPS70248	3.3V	1.5V	HTSSOP-20 (PWP)	-40°C to +125°C	TPS70248PWP	Tube, 70
					TPS70248PWPR	Tape and Reel, 2000
TPS70251	3.3V	1.8V	HTSSOP-20 (PWP)	-40°C to +125°C	TPS70251PWP	Tube, 70
					TPS70251PWPR	Tape and Reel, 2000
TPS70258	3.3V	2.5V	HTSSOP-20 (PWP)	-40°C to +125°C	TPS70258PWP	Tube, 70
					TPS70258PWPR	Tape and Reel, 2000

- (1) For the most current package and ordering information see the Package Option Addendum located at the end of this document, or see the TI web site at [www.ti.com](http://www.ti.com).
- (2) For fixed 1.20V operation, tie FB to OUT.

### ABSOLUTE MAXIMUM RATINGS<sup>(1)</sup>

Over operating free-air temperature range (unless otherwise noted).

	TPS702xx	UNIT
Input voltage range: V <sub>IN1</sub> , V <sub>IN2</sub> <sup>(2)</sup>	-0.3 to +7	V
Voltage range at $\overline{EN1}$ , $\overline{EN2}$	-0.3 to +7	V
Output voltage range (V <sub>OUT1</sub> , V <sub>SENSE1</sub> )	5.5	V
Output voltage range (V <sub>OUT2</sub> , V <sub>SENSE2</sub> )	5.5	V
Maximum RESET, PG1, PG2 voltage	7	V
Maximum MR voltage	V <sub>IN1</sub>	V
Peak output current	Internally limited	—
Continuous total power dissipation	See <a href="#">Dissipation Ratings Table</a>	—
Operating virtual junction temperature range, T <sub>J</sub>	-40 to +150	°C
Storage temperature range, T <sub>stg</sub>	-65 to +150	°C
ESD rating, HBM	2	kV

- (1) Stresses beyond those listed under absolute maximum ratings may cause permanent damage to the device. These are stress ratings only, and functional operation of the device at these or any other conditions beyond those indicated under recommended operating conditions is not implied. Exposure to absolute-maximum-rated conditions for extended periods may affect device reliability.
- (2) All voltages are tied to network ground.

## DISSIPATION RATINGS

PACKAGE	AIR FLOW (CFM)	T <sub>A</sub> ≤ +25°C	DERATING FACTOR	T <sub>A</sub> = +70°C	T <sub>A</sub> = +85°C
PWP <sup>(1)</sup>	0	3.067W	30.67mW/°C	1.687W	1.227W
	250	4.115W	41.15mW/°C	2.265W	1.646W

(1) This parameter is measured with the recommended copper heat sink pattern on a 4-layer PCB, 1 oz. copper on a 4-in by 4-in ground layer. For more information, refer to TI technical brief [SLMA002](#).

## RECOMMENDED OPERATING CONDITIONS

Over operating temperature range (unless otherwise noted).

	MIN	MAX	UNIT
Input voltage, V <sub>I</sub> <sup>(1)</sup> (regulator 1 and 2)	2.7	6	V
Output current, I <sub>O</sub> (regulator 1)	0	500	mA
Output current, I <sub>O</sub> (regulator 2)	0	250	mA
Output voltage range (for adjustable option)	1.22	5.5	V
Operating virtual junction temperature, T <sub>J</sub>	-40	+125	°C

(1) To calculate the minimum input voltage for maximum output current, use the following equation:  $V_{I(\min)} = V_{O(\max)} + V_{DO(\max \text{ load})}$ .

## ELECTRICAL CHARACTERISTICS

Over recommended operating junction temperature range ( $T_J = -40^\circ\text{C}$  to  $+125^\circ\text{C}$ ),  $V_{IN1}$  or  $V_{IN2} = V_{OUT(nom)} + 1\text{V}$ ,  $I_O = 1\text{mA}$ ,  $\overline{\text{EN}}1 = 0\text{V}$ ,  $\overline{\text{EN}}2 = 0\text{V}$ , and  $C_O = 33\mu\text{F}$  (unless otherwise noted).

PARAMETER		TEST CONDITIONS		MIN	TYP	MAX	UNIT	
$V_O$	Reference voltage	$2.7\text{V} < V_{IN} < 6\text{V}$ , $T_J = +25^\circ\text{C}$	FB connected to $V_O$		1.22		V	
		$2.7\text{V} < V_{IN} < 6\text{V}$ ,	FB connected to $V_O$	1.196		1.244		
	1.2V Output	$2.7\text{V} < V_{IN} < 6\text{V}$ ,	$T_J = +25^\circ\text{C}$		1.2			
		$2.7\text{V} < V_{IN} < 6\text{V}$ ,		1.176		1.224		
	1.5V Output	$2.7\text{V} < V_{IN} < 6\text{V}$ ,	$T_J = +25^\circ\text{C}$		1.5			
		$2.7\text{V} < V_{IN} < 6\text{V}$ ,		1.47		1.53		
	1.8V Output	$2.8\text{V} < V_{IN} < 6\text{V}$ ,	$T_J = +25^\circ\text{C}$		1.8			
		$2.8\text{V} < V_{IN} < 6\text{V}$ ,		1.764		1.836		
	2.5V Output	$3.5\text{V} < V_{IN} < 6\text{V}$ ,	$T_J = +25^\circ\text{C}$		2.5			
		$3.5\text{V} < V_{IN} < 6\text{V}$ ,		2.45		2.55		
3.3V Output	$4.3\text{V} < V_{IN} < 6\text{V}$ ,	$T_J = +25^\circ\text{C}$		3.3				
	$4.3\text{V} < V_{IN} < 6\text{V}$ ,		3.234		3.366			
Quiescent current (GND current) for regulator 1 and regulator 2, $\overline{\text{EN}}1 = \overline{\text{EN}}2 = 0\text{V}^{(1)}$		See <sup>(2)</sup>	$T_J = +25^\circ\text{C}$		190		$\mu\text{A}$	
		See <sup>(2)</sup>				230		
Output voltage line regulation ( $\Delta V_O/V_O$ ) for regulator 1 and regulator 2 <sup>(3)</sup>		$V_O + 1\text{V} < V_{IN} \leq 6\text{V}$ ,	$T_J = +25^\circ\text{C}^{(1)}$		0.01		%V	
		$V_O + 1\text{V} < V_{IN} \leq 6\text{V}$	<sup>(1)</sup>			0.1		
Load regulation for $V_{OUT1}$ and $V_{OUT2}$		$T_J = +25^\circ\text{C}$			1		mV	
$V_n$	Output noise voltage	Regulator 1	$\text{BW} = 300\text{Hz to } 50\text{kHz}$ , $C_O = 33\mu\text{F}$ , $T_J = +25^\circ\text{C}$		65		$\mu\text{V}_{\text{RMS}}$	
		Regulator 2			65			
Output current limit		Regulator 1	$V_{OUT} = 0\text{V}$		1.6	1.9	A	
		Regulator 2			0.750	1		
Thermal shutdown junction temperature					+150		$^\circ\text{C}$	
$I_I$ (standby)	Standby current	Regulator 1	$\overline{\text{EN}}1 = V_{IN}$ , $\overline{\text{EN}}2 = V_I$	$T_J = +25^\circ\text{C}$		2	$\mu\text{A}$	
		Regulator 2	$\overline{\text{EN}}1 = V_{IN}$ , $\overline{\text{EN}}2 = V_I$			6		
PSRR	Power-supply ripple rejection	Regulator 1	$f = 1\text{kHz}$ , $C_O = 33\mu\text{F}$ , $I_{OUT1} = 500\text{mA}$	$T_J = +25^\circ\text{C}^{(1)}$		60	dB	
		Regulator 2	$f = 1\text{kHz}$ , $C_O = 33\mu\text{F}$ , $I_{OUT2} = 250\text{mA}$	$T_J = +25^\circ\text{C}^{(1)}$		50		
UVLO threshold					2.4	2.65	V	
<b>RESET Terminal</b>								
Minimum input voltage for valid $\overline{\text{RESET}}$		$I_{\text{RESET}} = 300\mu\text{A}$ ,	$V_{(\text{RESET})} \leq 0.8\text{V}$		1.0	1.3	V	
$t_{(\text{RESET})}$		$\overline{\text{RESET}}$ pulse duration			80	120	160	ms
Output low voltage		$V_{IN} = 3.5\text{V}$ ,	$I_{(\text{RESET})} = 1\text{mA}$		0.15	0.4	V	
Leakage current		$V_{(\text{RESET})} = 6\text{V}$				1	$\mu\text{A}$	

(1) Minimum input operating voltage is  $2.7\text{V}$  or  $V_{O(\text{typ})} + 1\text{V}$ , whichever is greater. Maximum input voltage =  $6\text{V}$ , minimum output current =  $1\text{mA}$ .

(2)  $I_O = 1\text{mA}$  to  $500\text{mA}$  for Regulator 1 and  $1\text{mA}$  to  $250\text{mA}$  for Regulator 2.

(3) If  $V_O < 1.8\text{V}$  then  $V_{\text{Imax}} = 6\text{V}$ ,  $V_{\text{Imin}} = 2.7\text{V}$ :  
Line regulation (mV) = (%/V)  $\times V_O \frac{(V_{\text{Imax}} - 2.7)}{100} \times 1000$   
If  $V_O > 2.5\text{V}$  then  $V_{\text{Imax}} = 6\text{V}$ ,  $V_{\text{Imin}} = V_O + 1\text{V}$ :  
Line regulation (mV) = (%/V)  $\times V_O \frac{[V_{\text{Imax}} - (V_O + 1)]}{100} \times 1000$

## ELECTRICAL CHARACTERISTICS (continued)

Over recommended operating junction temperature range ( $T_J = -40^\circ\text{C}$  to  $+125^\circ\text{C}$ ),  $V_{IN1}$  or  $V_{IN2} = V_{OUT(nom)} + 1\text{V}$ ,  $I_O = 1\text{mA}$ ,  $\overline{EN1} = 0\text{V}$ ,  $\overline{EN2} = 0\text{V}$ , and  $C_O = 33\mu\text{F}$  (unless otherwise noted).

PARAMETER	TEST CONDITIONS	MIN	TYP	MAX	UNIT
<b>PG1/PG2 Terminal</b>					
Minimum input voltage for valid PGx	$I_{(PGx)} = 300\mu\text{A}$ , $V_{(PGx)} \leq 0.8\text{V}$		1.0	1.3	V
Trip threshold voltage	$V_O$ decreasing	92	95	98	% $V_{OUT}$
Hysteresis voltage	Measured at $V_O$		0.5		% $V_{OUT}$
$t_{r(PGx)}$	Rising edge deglitch		30		$\mu\text{s}$
Output low voltage	$V_{IN} = 2.7\text{V}$ , $I_{(PGx)} = 1\text{mA}$		0.15	0.4	V
Leakage current	$V_{(PGx)} = 6\text{V}$			1	$\mu\text{A}$
<b>EN1/EN2 Terminal</b>					
High-level $\overline{ENx}$ input voltage		2			V
Low-level $\overline{ENx}$ input voltage				0.7	V
Input current ( $\overline{ENx}$ )		-1		1	$\mu\text{A}$
<b><math>\overline{MR}</math> Terminal</b>					
High-level input voltage		2			V
Low-level input voltage				0.7	V
Pull-up current source			6		$\mu\text{A}$
<b><math>V_{OUT1}</math> Terminal</b>					
Dropout voltage <sup>(4)</sup>	$I_O = 500\text{mA}$ , $V_{IN1} = 3.2\text{V}$ $T_J = +25^\circ\text{C}$		170		mV
	$I_O = 500\text{mA}$ , $V_{IN1} = 3.2\text{V}$			275	
Peak output current	2ms pulse width		750		mA
Discharge transistor current	$V_{OUT1} = 1.5\text{V}$		7.5		mA
<b><math>V_{OUT2}</math> Terminal</b>					
Peak output current	2ms pulse width		375		mA
Discharge transistor current	$V_{OUT2} = 1.5\text{V}$		7.5		mA
<b>FB Terminal</b>					
Input current: TPS70202	FB = 1.8V		1		$\mu\text{A}$

(4) Input voltage ( $V_{IN1}$  or  $V_{IN2}$ ) =  $V_{O(typ)} - 100\text{mV}$ . For 1.5V, 1.8V and 2.5V regulators, the dropout voltage is limited by input voltage range. The 3.3V regulator input is set to 3.2V to perform this test.

DEVICE INFORMATION  
Fixed Voltage Version

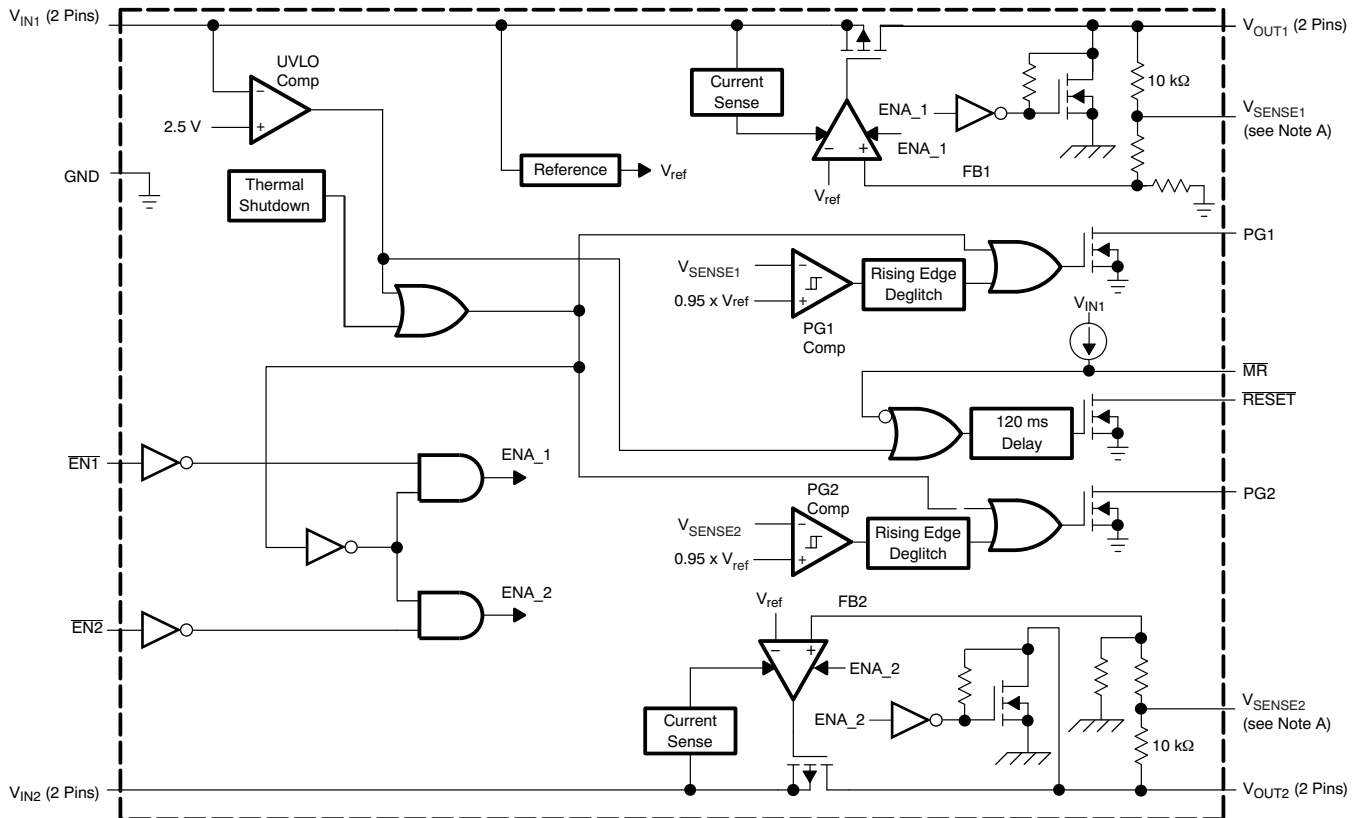

- A. For most applications,  $V_{SENSE1}$  and  $V_{SENSE2}$  should be externally connected to  $V_{OUT1}$  and  $V_{OUT2}$ , respectively, as close as possible to the device. For other implementations, refer to SENSE terminal connection discussion in the [Application Information](#) section.

Adjustable Voltage Version

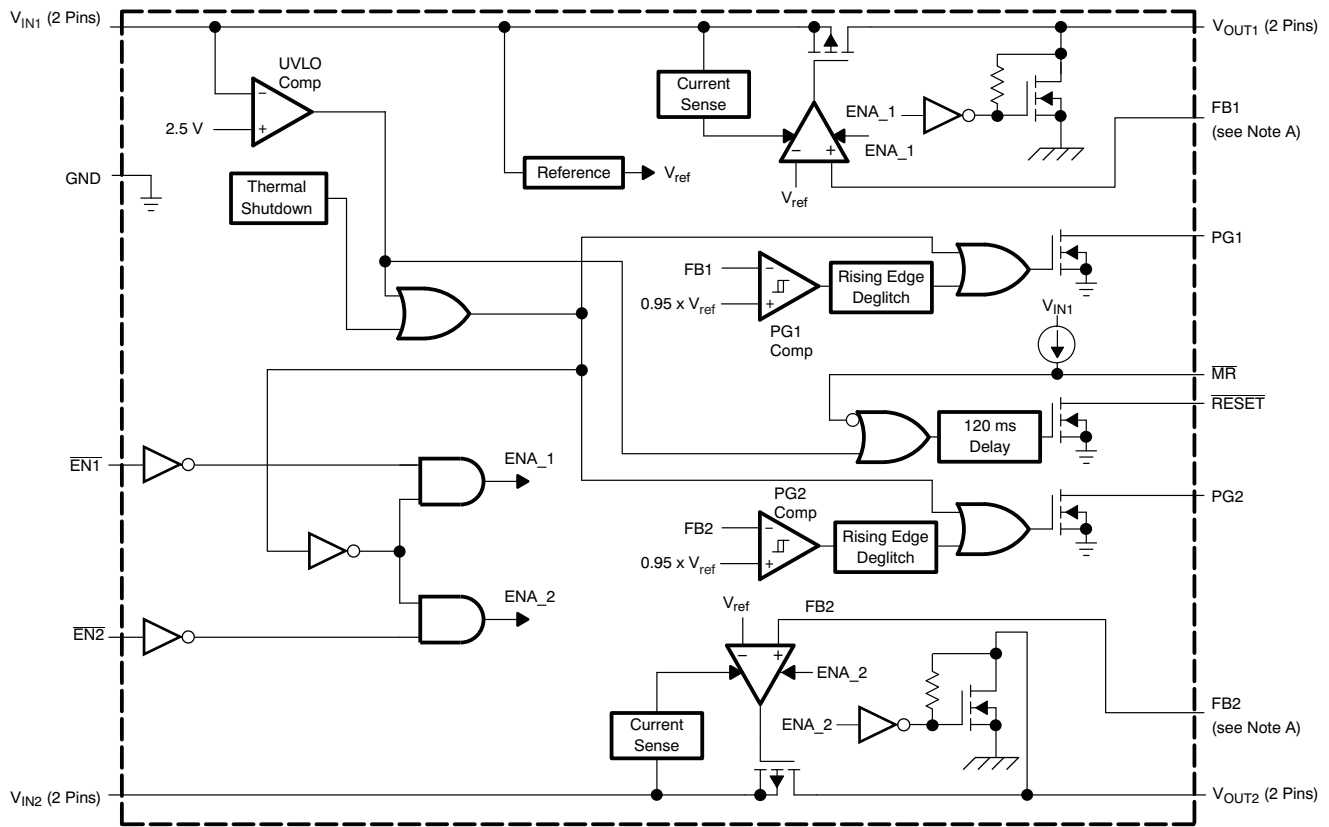

- A. For most applications, FB1 and FB2 should be externally connected to resistor dividers as close as possible to the device. For other implementations, refer to FB terminals connection discussion in the [Application Information](#) section.

### RESET Timing Diagram

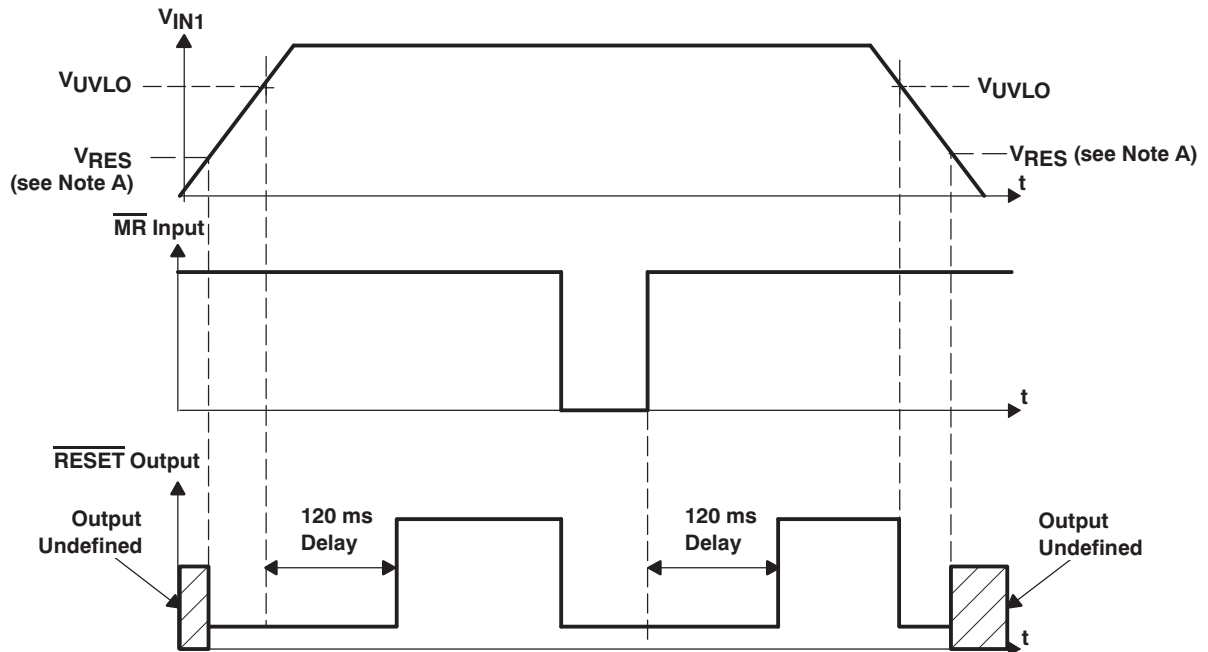

NOTE A:  $V_{RES}$  is the minimum input voltage for a valid  $\overline{RESET}$ . The symbol  $V_{RES}$  is not currently listed within EIA or JEDEC standards for semiconductor symbology.

### PG1 Timing Diagram

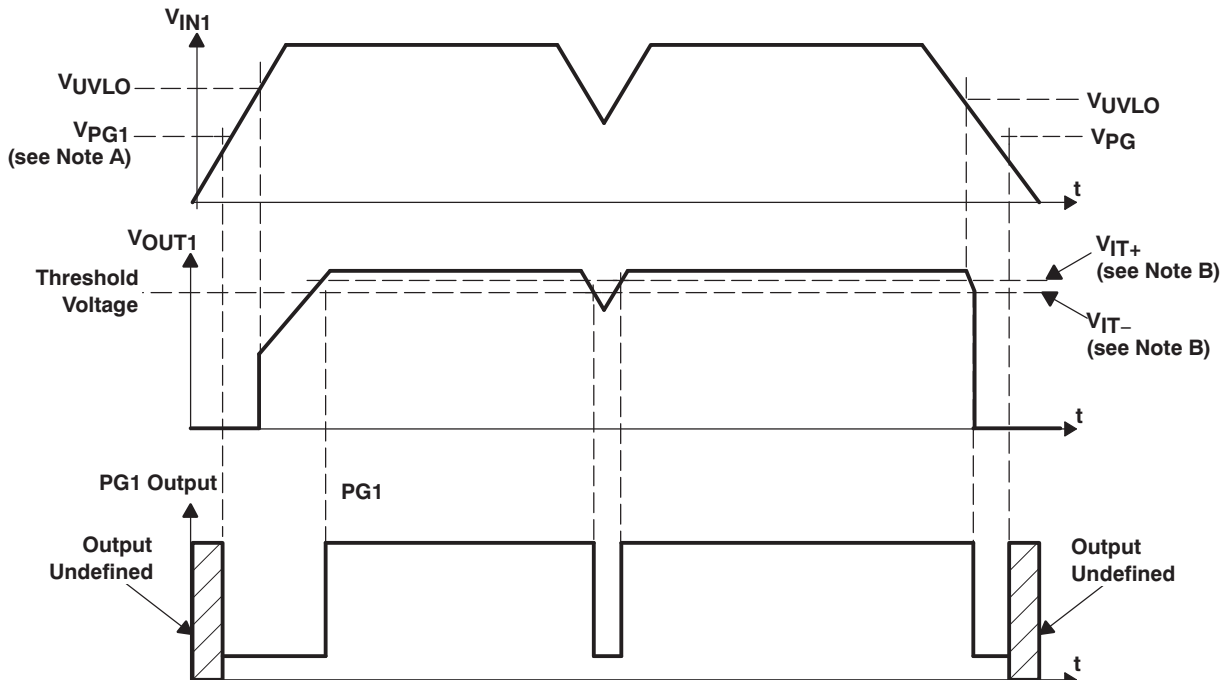

NOTES: A.  $V_{PG1}$  is the minimum input voltage for a valid  $PG1$ . The symbol  $V_{PG1}$  is not currently listed within EIA or JEDEC standards for semiconductor symbology.

B.  $V_{IT-}$  trip voltage is typically 5% lower than the output voltage ( $95\%V_O$ ).  $V_{IT-}$  to  $V_{IT+}$  is the hysteresis voltage.

PG2 Timing Diagram (assuming  $V_{IN1}$  already powered up)

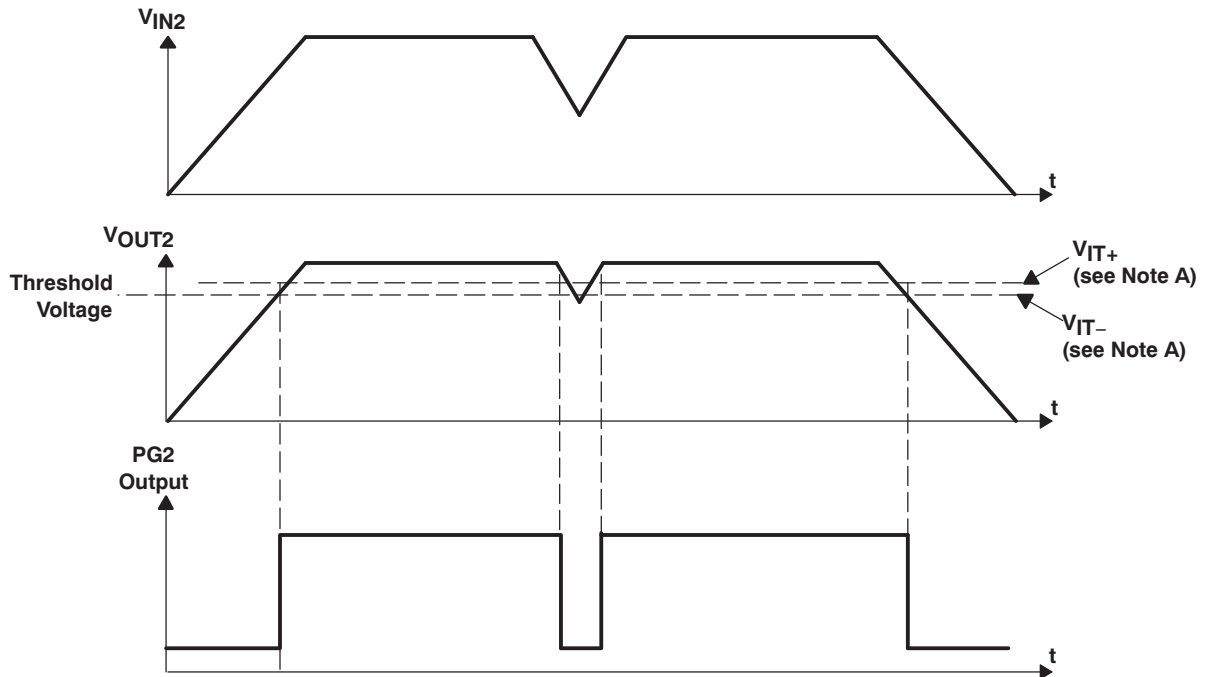

NOTE A:  $V_{IT-}$  trip voltage is typically 5% lower than the output voltage ( $95\%V_O$ ).  $V_{IT-}$  to  $V_{IT+}$  is the hysteresis voltage.

### TERMINAL FUNCTIONS

TERMINAL		I/O	DESCRIPTION
NAME	NO.		
$\overline{EN1}$	5	I	Active low enable for $V_{OUT1}$
$\overline{EN2}$	6	I	Active low enable for $V_{OUT2}$
GND	8	—	Ground
$\overline{MR}$	4	I	Manual reset input, active low, pulled up internally
NC	1, 11, 20	—	No connection
PG1	16	O	Open drain output, low when $V_{OUT1}$ voltage is less than 95% of the nominal regulated voltage
PG2	15	O	Open drain output, low when $V_{OUT2}$ voltage is less than 95% of the nominal regulated voltage
$\overline{RESET}$	7	I	Open drain output, SVS (power-on reset) signal, active low
$V_{IN1}$	2, 3	I	Input voltage of regulator 1
$V_{IN2}$	9, 10	I	Input voltage of regulator 2
$V_{OUT1}$	18, 19	O	Output voltage of regulator 1
$V_{OUT2}$	12, 13	O	Output voltage of regulator 2
$V_{SENSE2}/FB2$	14	I	Regulator 2 output voltage sense/regulator 2 feedback for adjustable
$V_{SENSE1}/FB1$	17	I	Regulator 1 output voltage sense/regulator 1 feedback for adjustable

## Detailed Description

The TPS702xx low dropout regulator family provides dual regulated output voltages with independent enable functions. These devices provide fast transient response and high accuracy with small output capacitors, while drawing low quiescent current. Other features are integrated SVS (power-on reset,  $\overline{\text{RESET}}$ ) and power good (PG1, PG2) that monitor output voltages and provide logic output to the system. These differentiated features provide a complete power solution.

The TPS702xx, unlike many other LDOs, features very low quiescent current that remains virtually constant even with varying loads. Conventional LDO regulators use a pnp pass element, the base current of which is directly proportional to the load current through the regulator ( $I_B = I_C/\beta$ ). The TPS702xx uses a PMOS transistor to pass current; the gate of the PMOS is voltage-driven, so operating current is low and stable over the full load range.

## Pin Functions

### Enable ( $\overline{\text{EN1}}$ , $\overline{\text{EN2}}$ )

The  $\overline{\text{EN}}$  terminals are inputs that enable or shut down each respective regulator. If  $\overline{\text{EN}}$  is at a voltage high signal, the respective regulator is in shutdown mode. When  $\overline{\text{EN}}$  goes to voltage low, the respective regulator is enabled.

### Power-Good (PG1, PG2)

The PG terminals are open drain, active high output terminals that indicate the status of each respective regulator. When  $V_{\text{OUT1}}$  reaches 95% of its regulated voltage, PG1 goes to a high impedance state. When  $V_{\text{OUT2}}$  reaches 95% of its regulated voltage, PG2 goes to a high impedance state. Each PG goes to a low impedance state when its respective output voltage is pulled below 95% (that is, goes to an overload condition) of its regulated voltage. The open drain outputs of the PG terminals require a pull-up resistor.

### Manual Reset Pin

$\overline{\text{MR}}$  is an active low input terminal used to trigger a reset condition. When  $\overline{\text{MR}}$  is pulled to logic low, a POR ( $\overline{\text{RESET}}$ ) occurs. The terminal has a 6 $\mu\text{A}$  pull-up current to  $V_{\text{IN1}}$ .

### Sense ( $V_{\text{SENSE1}}$ , $V_{\text{SENSE2}}$ )

The sense terminals of fixed-output options must be connected to the regulator outputs, and the connection should be as short as possible. Internally, the sense terminal connects to high-impedance, wide-bandwidth amplifiers through a resistor-divider network and noise pickup feeds through to the regulator output. It is essential to route the sense connection in such a way as to minimize or avoid noise pickup. Adding RC networks between sense terminals and  $V_{\text{OUT}}$  terminals to filter noise is not recommended because these networks can cause the regulators to oscillate.

## FB1 and FB2

FB1 and FB2 are input terminals used for adjustable-output devices and must be connected to the external feedback resistor divider. FB1 and FB2 connections should be as short as possible. It is essential to route them in such a way as to minimize or avoid noise pickup. Adding RC networks between FB terminals and  $V_{OUT}$  terminals to filter noise is not recommended because these networks can cause the regulators to oscillate.

## RESET Indicator

The TPS702xx features a  $\overline{\text{RESET}}$  (SVS, POR, or power on reset).  $\overline{\text{RESET}}$  can be used to drive power on reset circuitry or a low-battery indicator.  $\overline{\text{RESET}}$  is an active low, open drain output that indicates the status of the manual reset pin (MR). When MR is in a high impedance state,  $\overline{\text{RESET}}$  goes to a high impedance state after a 120 ms delay. To monitor  $V_{OUT1}$ , the PG1 output pin can be connected to MR. To monitor  $V_{OUT2}$ , the PG2 output pin can be connected to MR. The open drain output of the  $\overline{\text{RESET}}$  terminal requires a pull-up resistor. If  $\overline{\text{RESET}}$  is not used, it can be left floating.

## $V_{IN1}$ and $V_{IN2}$

$V_{IN1}$  and  $V_{IN2}$  are inputs to each regulator. **Internal bias voltages are powered by  $V_{IN1}$ .**

## $V_{OUT1}$ and $V_{OUT2}$

$V_{OUT1}$  and  $V_{OUT2}$  are output terminals of each regulator.

## TYPICAL CHARACTERISTICS

Table of Graphs

			FIGURE
$V_O$	Output voltage	vs Output current	Figure 1 to Figure 3
		vs Junction temperature	Figure 4 to Figure 5
	Ground current	vs Junction temperature	Figure 6
PSRR	Power-supply rejection ratio	vs Frequency	Figure 7 to Figure 10
		Output spectral noise density	vs Frequency
$Z_O$	Output impedance	vs Frequency	Figure 15 to Figure 18
		vs Temperature	Figure 19 and Figure 20
		vs Input voltage	Figure 21 and Figure 22
	Load transient response		Figure 23 and Figure 24
	Line transient response ( $V_{OUT1}$ )		Figure 25
	Line transient response ( $V_{OUT2}$ )		Figure 26
$V_O$	Output voltage	vs Time (start-up)	Figure 27 and Figure 28
		Equivalent series resistance (ESR)	vs Output current

TPS70251  
OUTPUT VOLTAGE  
vs  
OUTPUT CURRENT

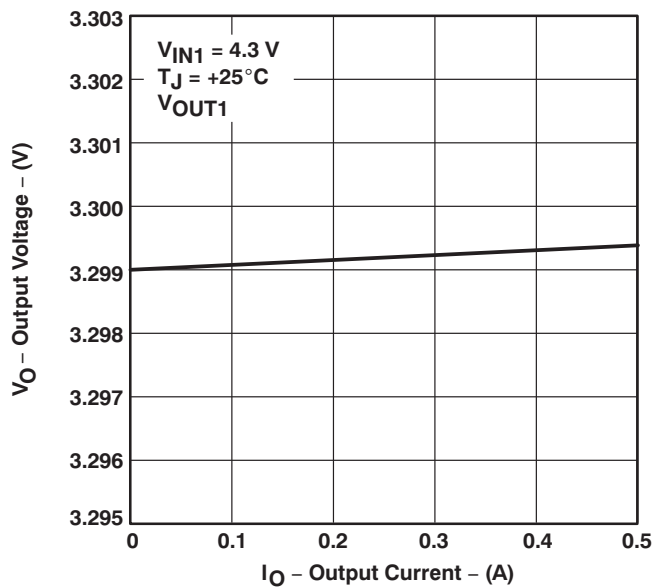

Figure 1.

TPS70251  
OUTPUT VOLTAGE  
vs  
OUTPUT CURRENT

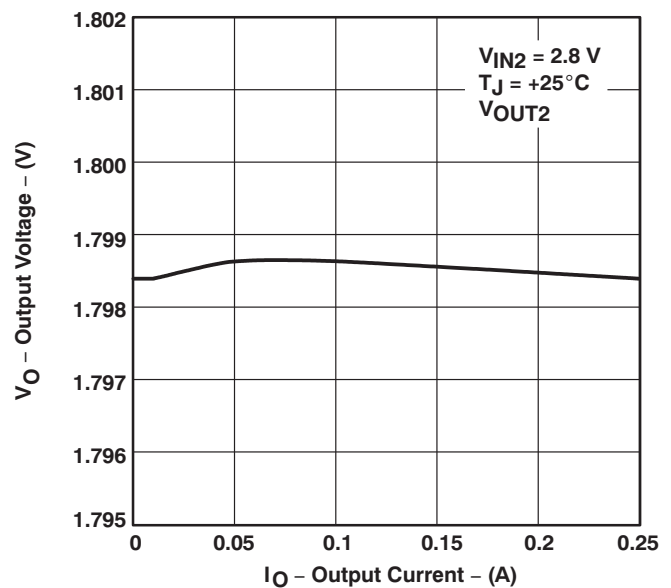

Figure 2.

TYPICAL CHARACTERISTICS (continued)

TPS70245  
 OUTPUT VOLTAGE  
 vs  
 OUTPUT CURRENT

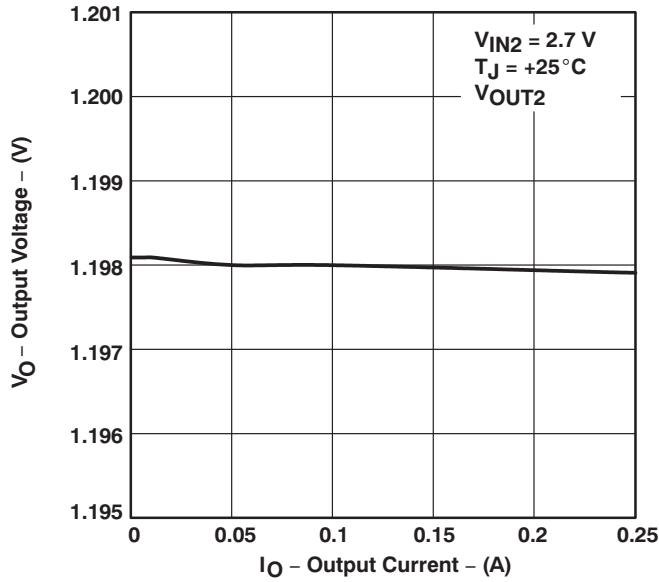

Figure 3.

TPS70251  
 OUTPUT VOLTAGE  
 vs  
 JUNCTION TEMPERATURE

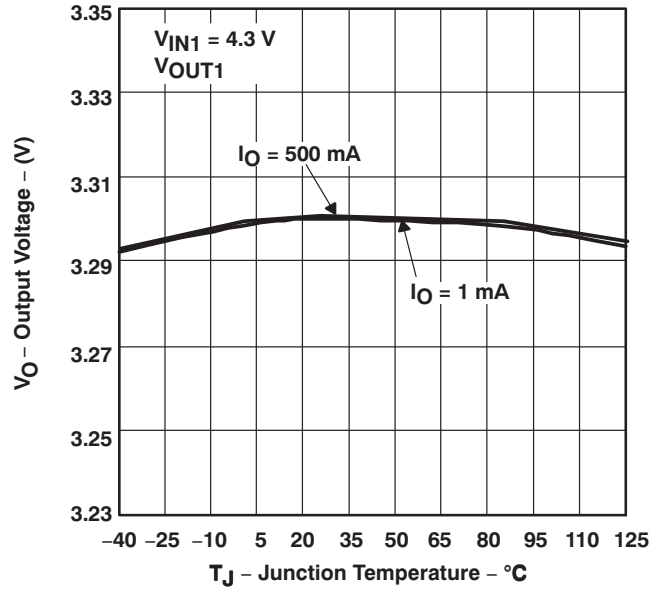

Figure 4.

TPS70251  
 OUTPUT VOLTAGE  
 vs  
 JUNCTION TEMPERATURE

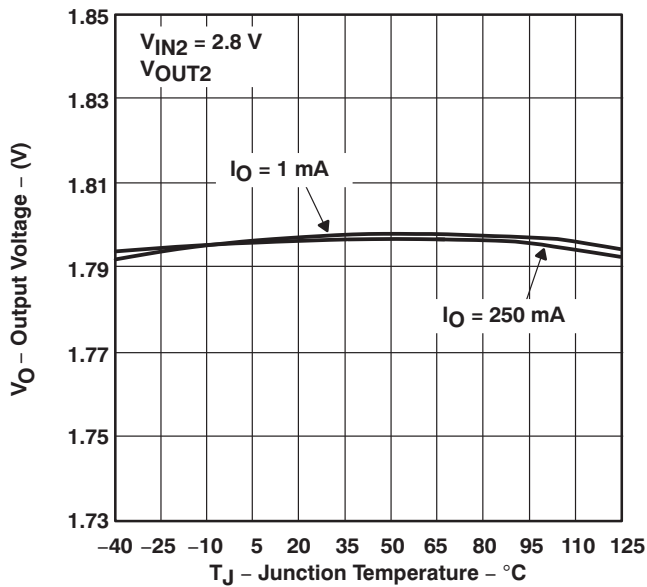

Figure 5.

GROUND CURRENT  
 vs  
 JUNCTION TEMPERATURE

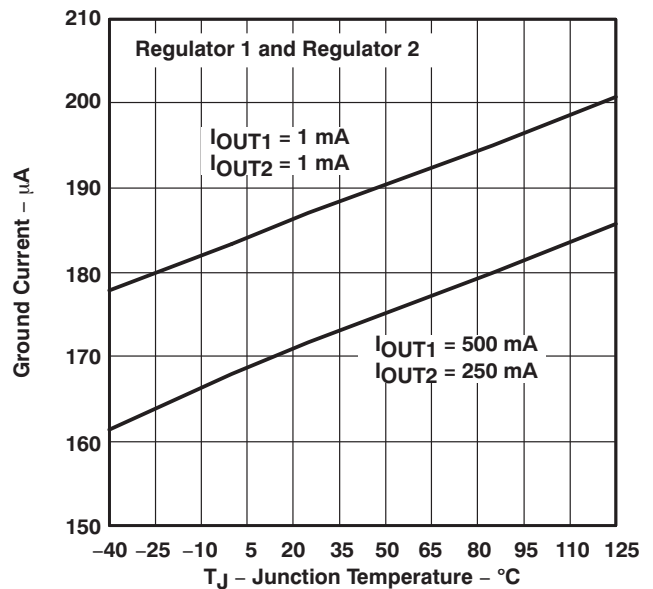

Figure 6.

TYPICAL CHARACTERISTICS (continued)

TPS70251  
POWER-SUPPLY REJECTION RATIO  
vs  
FREQUENCY

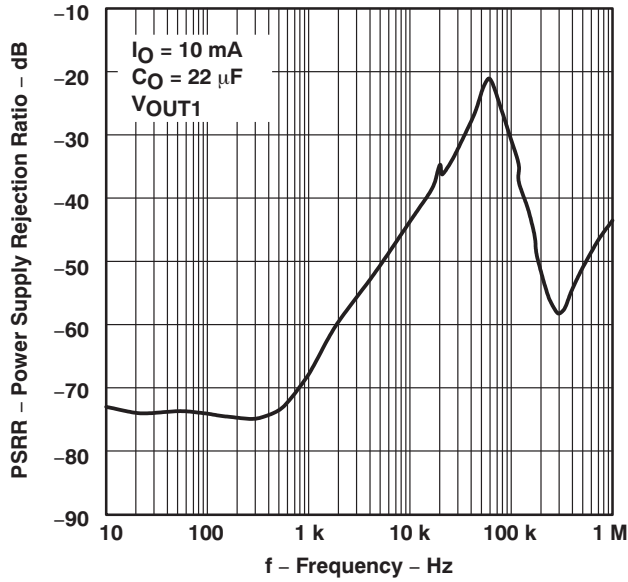

Figure 7.

TPS70251  
POWER-SUPPLY REJECTION RATIO  
vs  
FREQUENCY

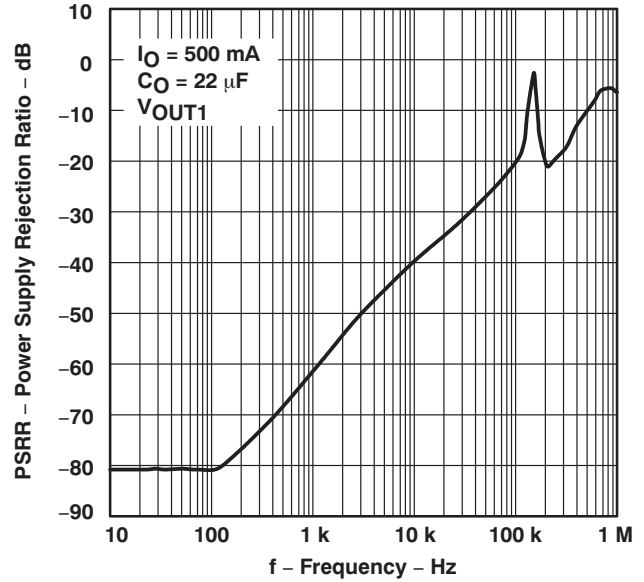

Figure 8.

TPS70251  
POWER-SUPPLY REJECTION RATIO  
vs  
FREQUENCY

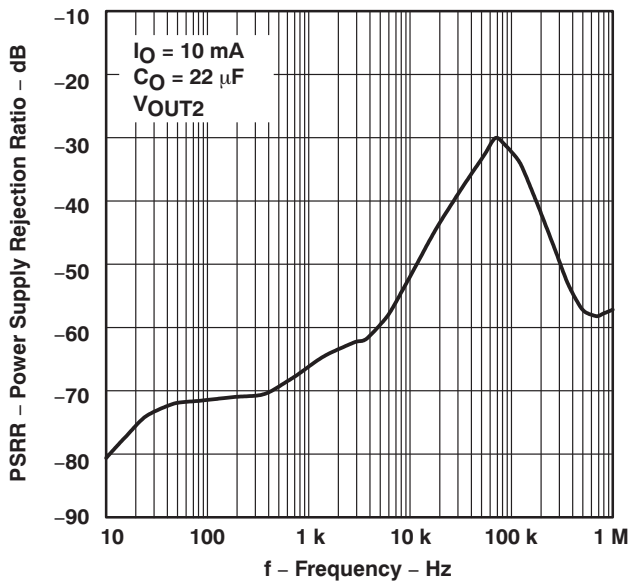

Figure 9.

TPS70251  
POWER-SUPPLY REJECTION RATIO  
vs  
FREQUENCY

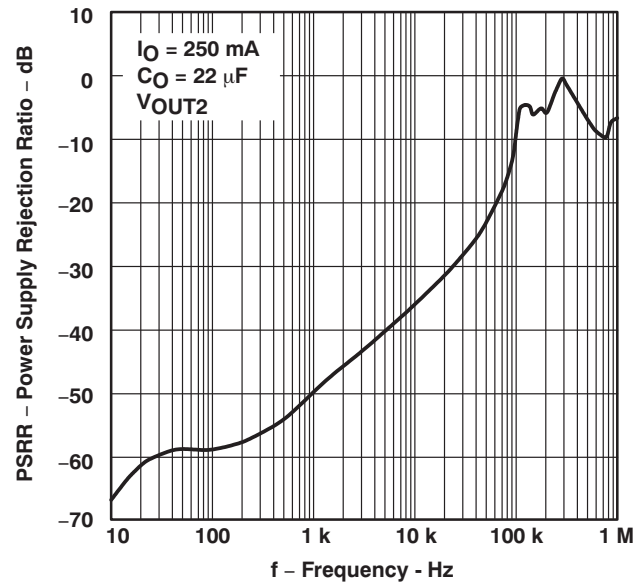

Figure 10.

TYPICAL CHARACTERISTICS (continued)

OUTPUT SPECTRAL NOISE DENSITY  
 VS  
 FREQUENCY

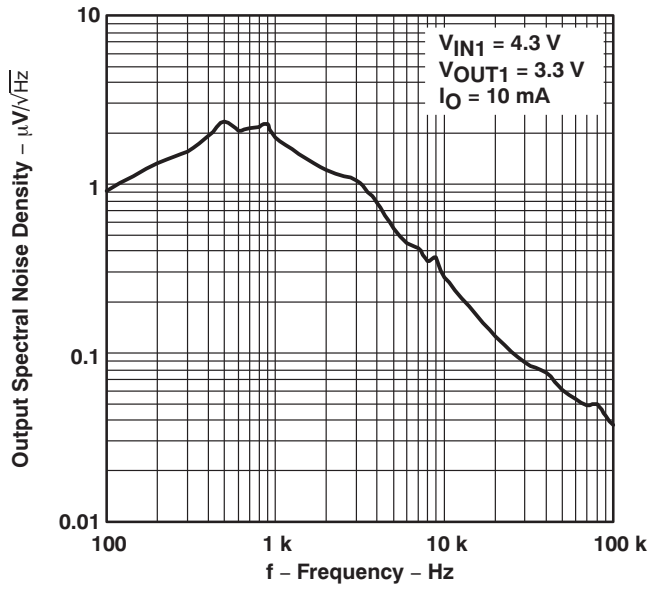

Figure 11.

OUTPUT SPECTRAL NOISE DENSITY  
 VS  
 FREQUENCY

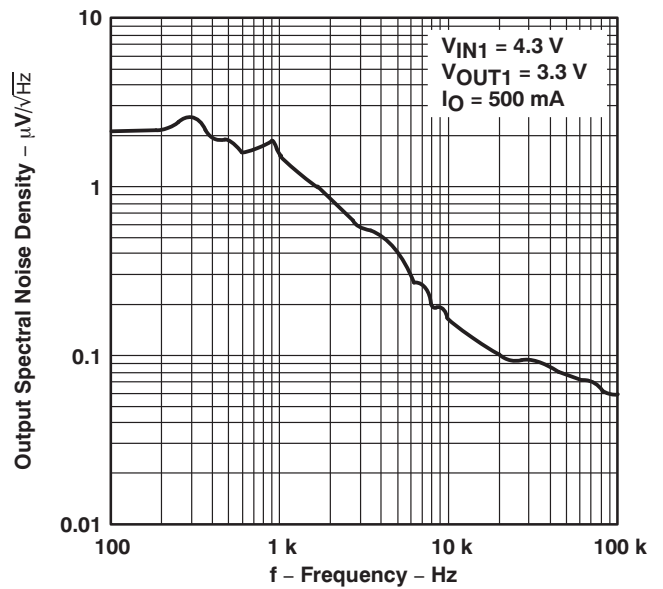

Figure 12.

OUTPUT SPECTRAL NOISE DENSITY  
 VS  
 FREQUENCY

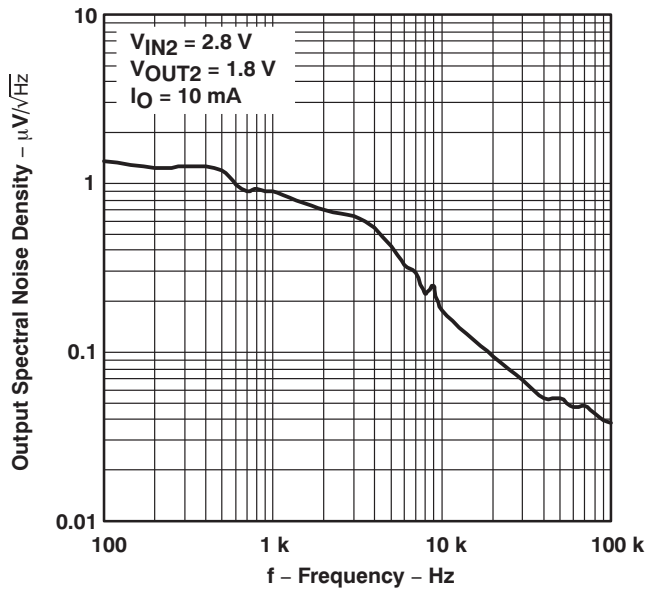

Figure 13.

OUTPUT SPECTRAL NOISE DENSITY  
 VS  
 FREQUENCY

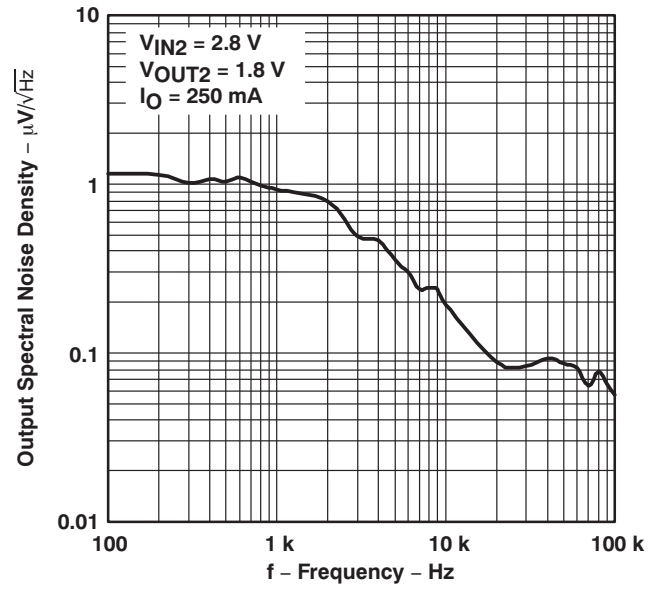

Figure 14.

TYPICAL CHARACTERISTICS (continued)

OUTPUT IMPEDANCE  
vs  
FREQUENCY

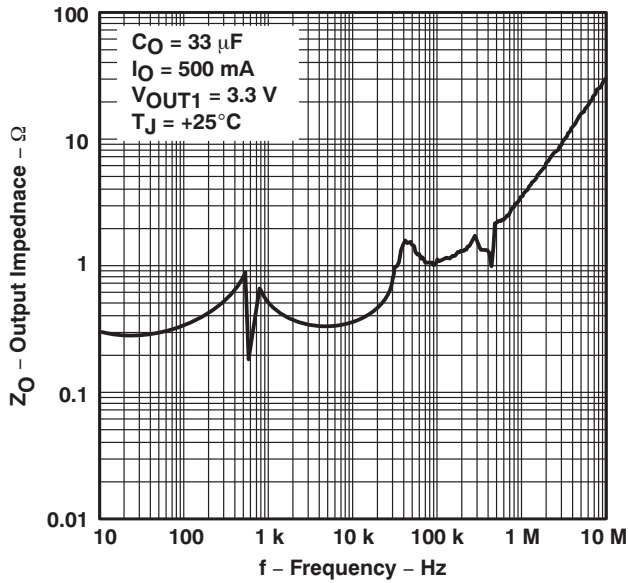

Figure 15.

OUTPUT IMPEDANCE  
vs  
FREQUENCY

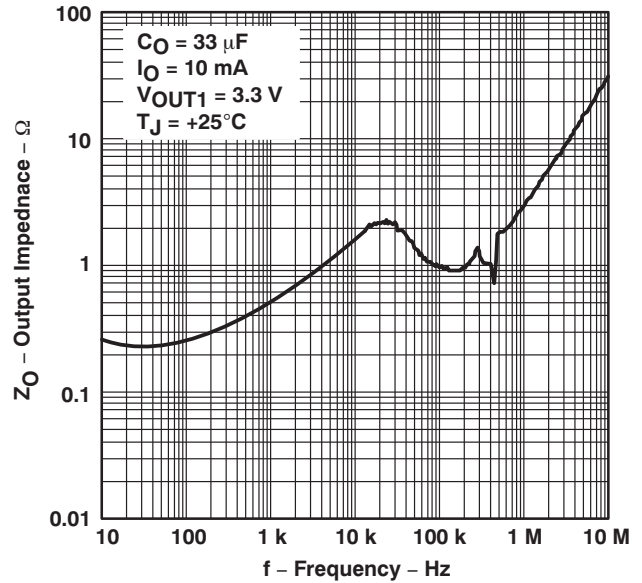

Figure 16.

OUTPUT IMPEDANCE  
vs  
FREQUENCY

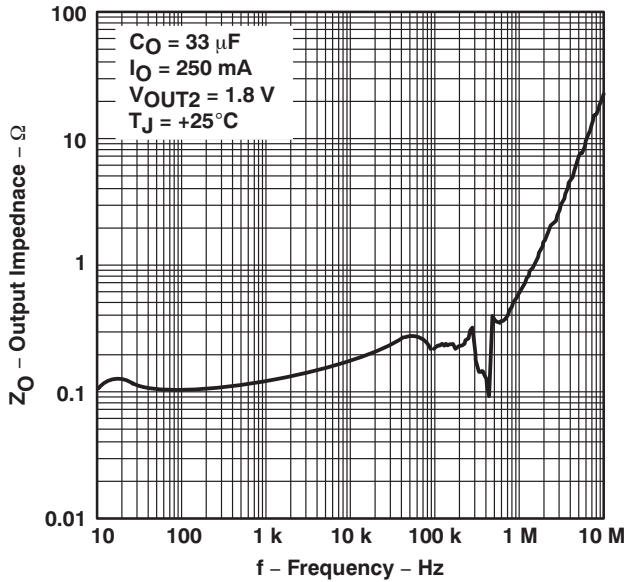

Figure 17.

OUTPUT IMPEDANCE  
vs  
FREQUENCY

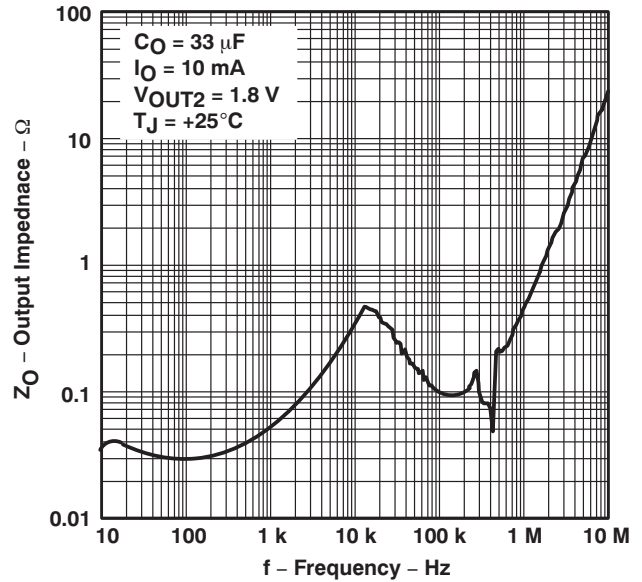

Figure 18.

TYPICAL CHARACTERISTICS (continued)

DROPOUT VOLTAGE  
 vs  
 TEMPERATURE

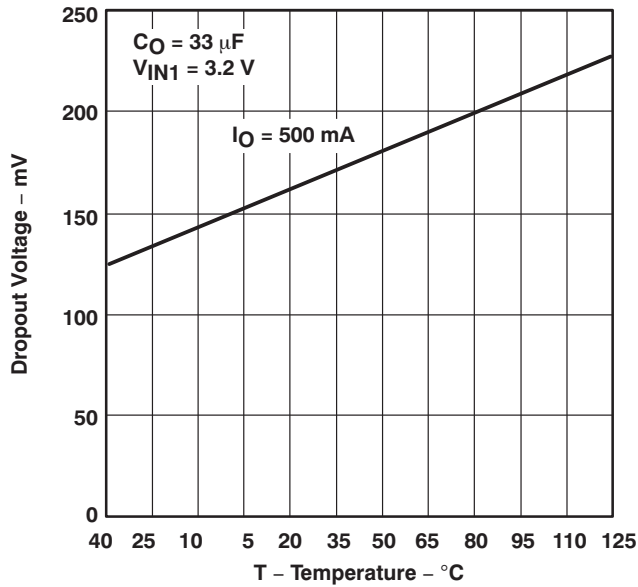

Figure 19.

DROPOUT VOLTAGE  
 vs  
 TEMPERATURE

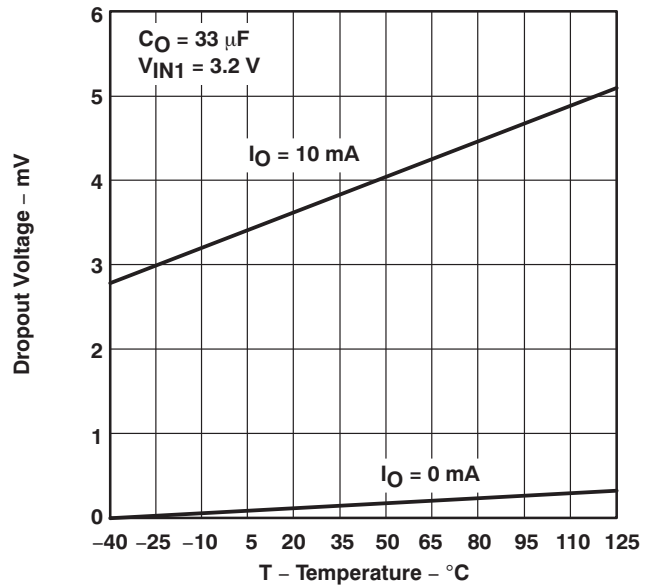

Figure 20.

TPS70202  
 DROPOUT VOLTAGE  
 vs  
 INPUT VOLTAGE

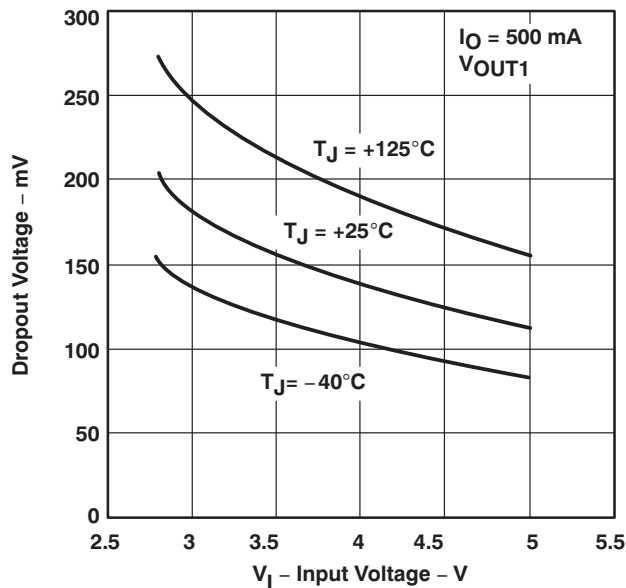

Figure 21.

TPS70202  
 DROPOUT VOLTAGE  
 vs  
 INPUT VOLTAGE

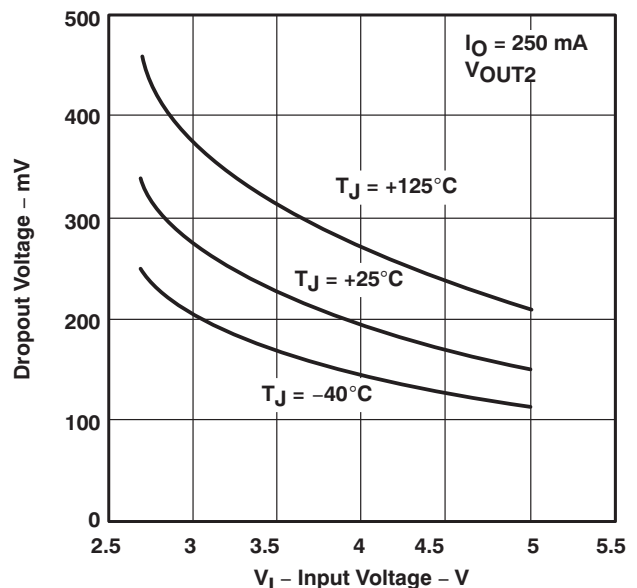

Figure 22.

TYPICAL CHARACTERISTICS (continued)

LOAD TRANSIENT RESPONSE

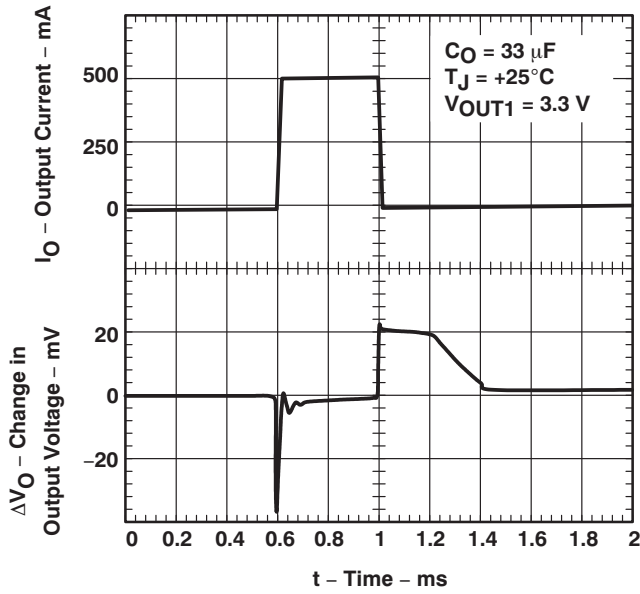

Figure 23.

LOAD TRANSIENT RESPONSE

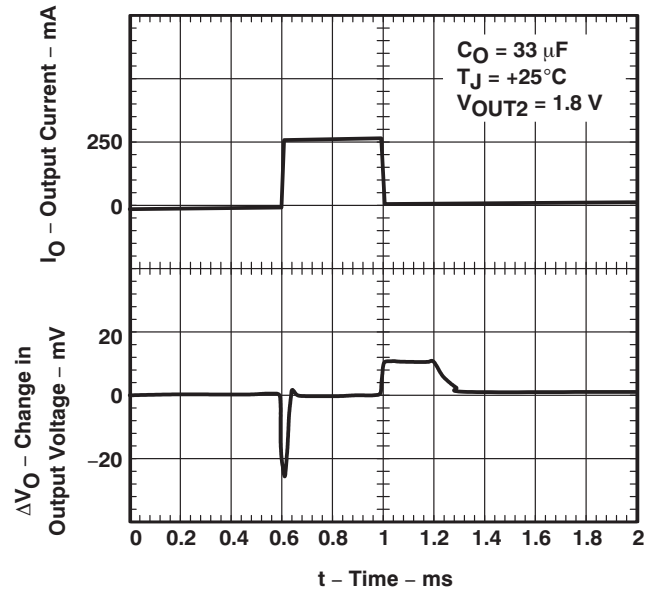

Figure 24.

LINE TRANSIENT RESPONSE

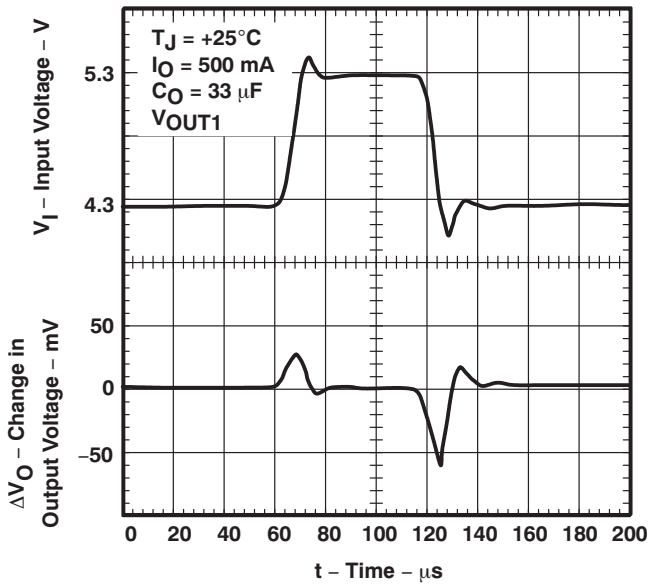

Figure 25.

LINE TRANSIENT RESPONSE

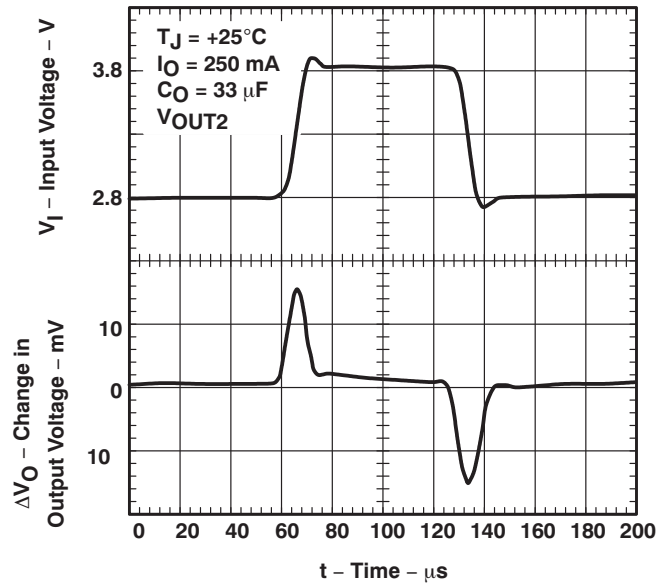

Figure 26.

TYPICAL CHARACTERISTICS (continued)

OUTPUT VOLTAGE AND ENABLE VOLTAGE  
 VS  
 TIME (START-UP)

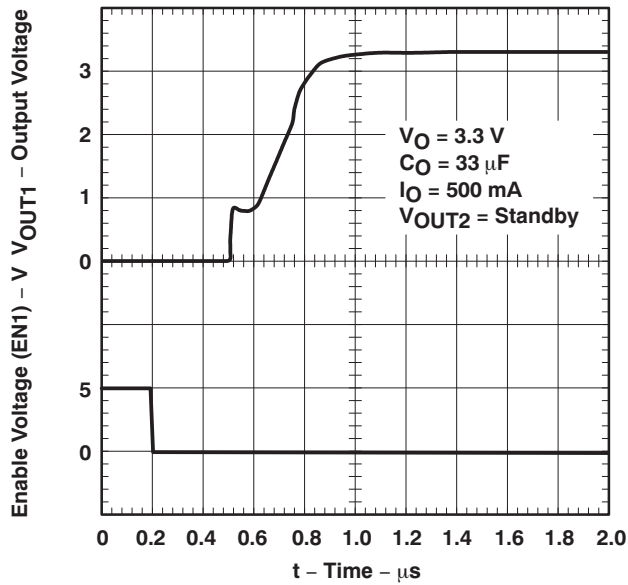

Figure 27.

OUTPUT VOLTAGE AND ENABLE VOLTAGE  
 VS  
 TIME (START-UP)

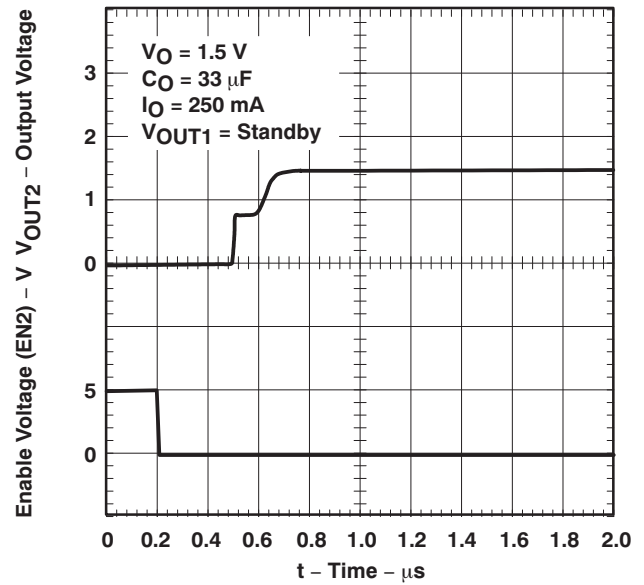

Figure 28.

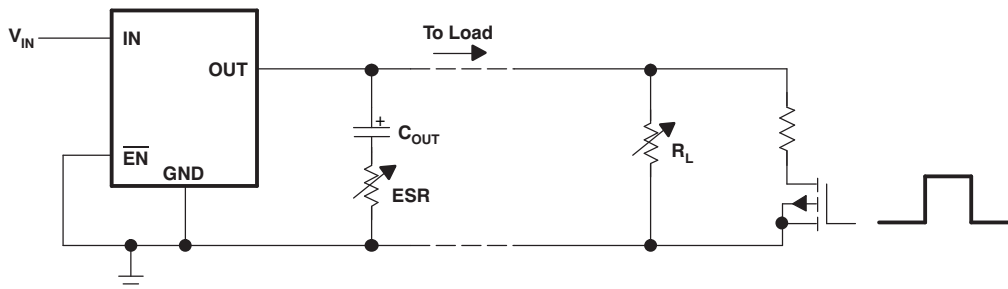

Figure 29. Test Circuit for Typical Regions of Stability

TYPICAL CHARACTERISTICS (continued)

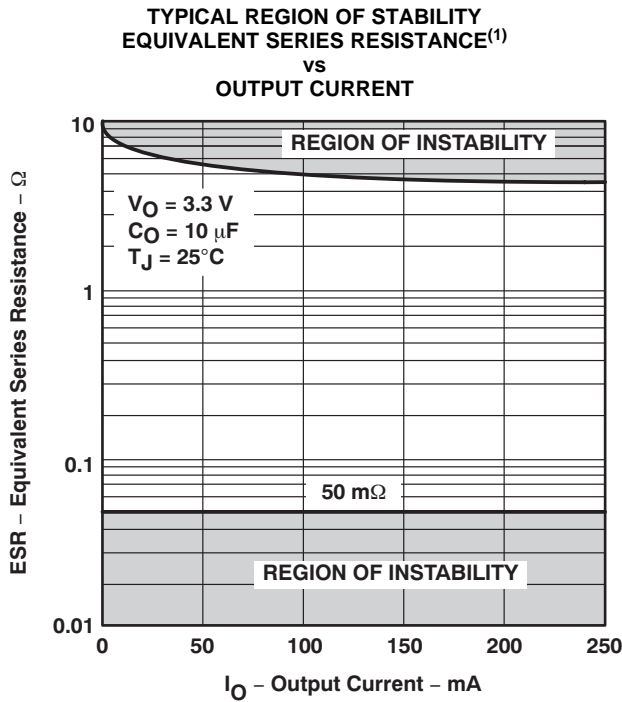

Figure 30.

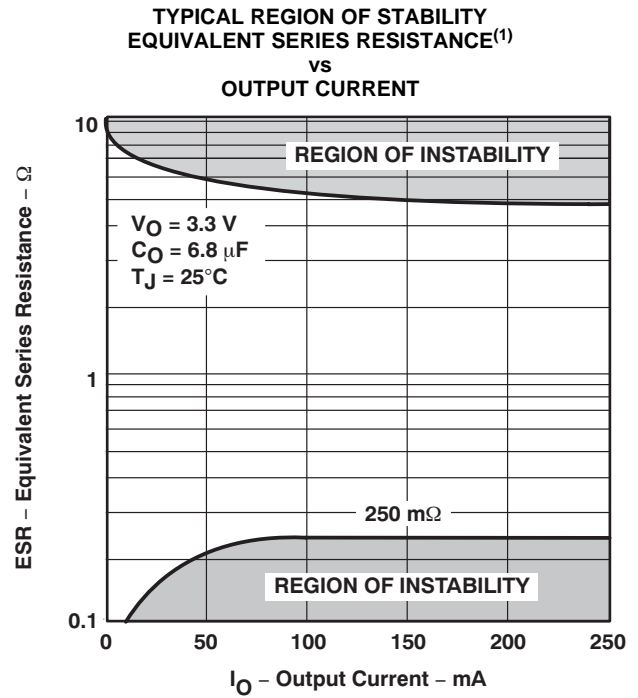

Figure 31.

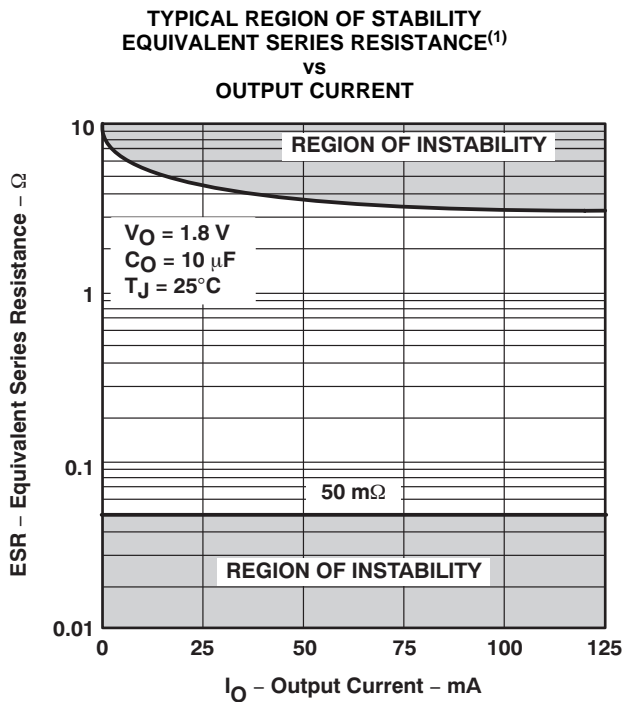

Figure 32.

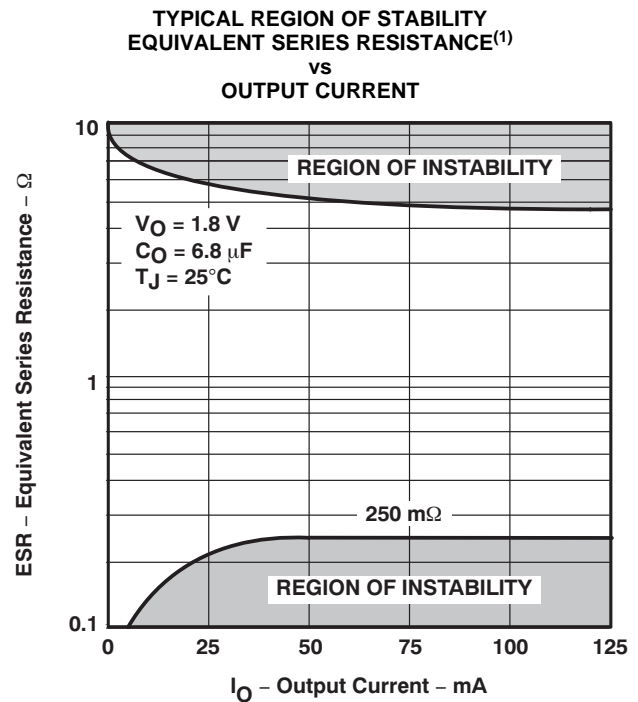

Figure 33.

<sup>(1)</sup> Equivalent series resistance (ESR) refers to the total series resistance, including the ESR of the capacitor, any series resistance added externally, and PWB trace resistance to  $C_O$ .

## APPLICATION INFORMATION

### Sequencing Timing Diagrams

This section provides a number of timing diagrams showing how this device functions in different configurations.

**Application condition:**  $V_{IN1}$  and  $V_{IN2}$  are tied to the same fixed input voltage greater than  $V_{UVLO}$ .  $\overline{PG2}$  is tied to  $\overline{MR}$ .

$\overline{EN1}$  and  $\overline{EN2}$  are initially high; therefore, both regulators are off, and  $\overline{PG1}$  and  $\overline{PG2}$  (tied to  $\overline{MR}$ ) are at logic low. Since  $\overline{MR}$  is at logic low,  $\overline{RESET}$  is also at logic low. When  $\overline{EN1}$  is taken to logic low,  $V_{OUT1}$  turns on. Later, when  $\overline{EN2}$  is taken to logic low,  $V_{OUT2}$  turns on. When  $V_{OUT1}$  reaches 95% of its regulated output voltage,  $\overline{PG1}$  goes to logic high. When  $V_{OUT2}$  reaches 95% of its regulated output voltage,  $\overline{PG2}$  (tied to  $\overline{MR}$ ) goes to logic high. When  $V_{IN1}$  is greater than  $V_{UVLO}$  and  $\overline{MR}$  (tied to  $\overline{PG2}$ ) is at logic high,  $\overline{RESET}$  is pulled to logic high after a 120ms delay. When  $\overline{EN1}$  and  $\overline{EN2}$  are returned to logic high, both devices power down and both  $\overline{PG1}$ ,  $\overline{PG2}$  (tied to  $\overline{MR2}$ ), and  $\overline{RESET}$  return to logic low.

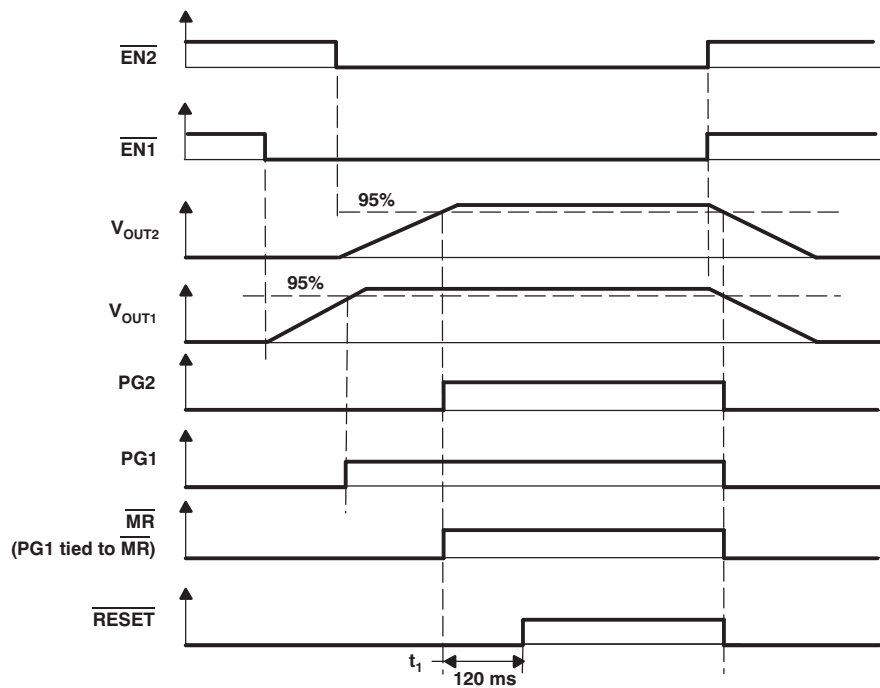
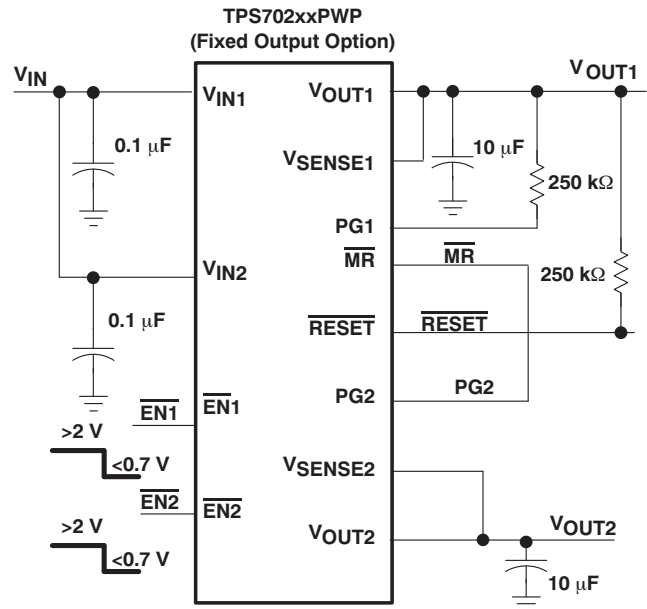

NOTES: A.  $t_1$ : Time at which  $V_{IN}$  is greater than  $V_{UVLO}$  and  $\overline{MR}$  is logic high.  
 B. The timing diagram is not drawn to scale.

**Figure 34. Timing When  $V_{OUT1}$  Is Enabled Before  $V_{OUT2}$**

**Application condition:**  $V_{IN1}$  and  $V_{IN2}$  are tied to the same fixed input voltage greater than  $V_{UVLO}$ .  $\overline{MR}$  is initially logic high but is eventually toggled.

$\overline{EN1}$  and  $\overline{EN2}$  are initially high; therefore, both regulators are off, and PG1 and PG2 are at logic low. Since  $V_{IN1}$  is greater than  $V_{UVLO}$  and  $\overline{MR}$  is at logic high,  $\overline{RESET}$  is also at logic high. When  $\overline{EN2}$  is taken to logic low,  $V_{OUT2}$  turns on. Later, when  $\overline{EN1}$  is taken to logic low,  $V_{OUT1}$  turns on. When  $V_{OUT2}$  reaches 95% of its regulated output voltage, PG2 goes to logic high. When  $V_{OUT1}$  reaches 95% of its regulated output voltage, PG1 goes to logic high. When  $\overline{MR}$  is taken to logic low,  $\overline{RESET}$  is taken low. When  $\overline{MR}$  returns to logic high,  $\overline{RESET}$  returns to logic high after a 120ms delay.

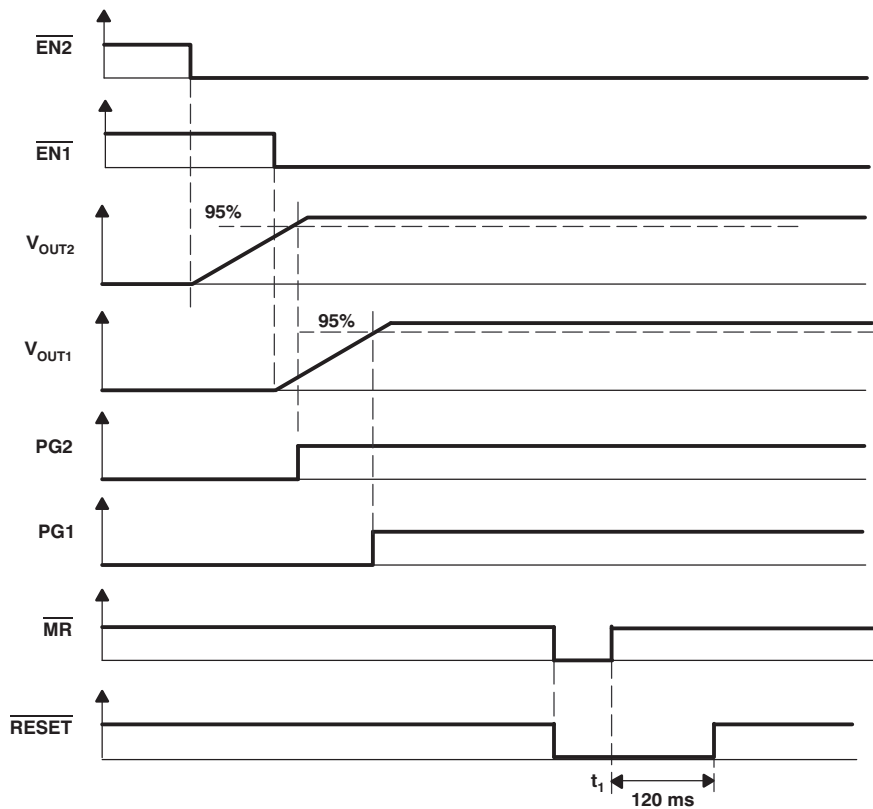
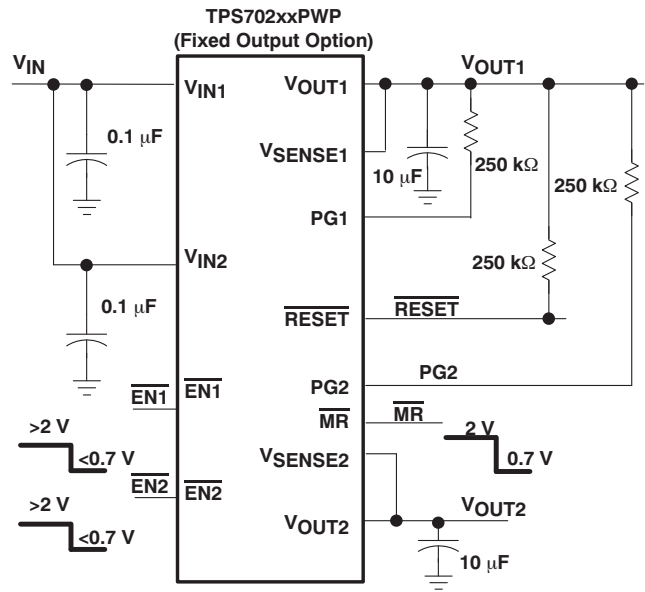

NOTES: A.  $t_1$ : Time at which  $V_{IN}$  is greater than  $V_{UVLO}$  and  $\overline{MR}$  is logic high.  
B. The timing diagram is not drawn to scale.

**Figure 35. Timing When  $\overline{MR}$  is Toggled**

**Application condition:**  $V_{IN1}$  and  $V_{IN2}$  are tied to same fixed input voltage greater than  $V_{UVLO}$ .  $\overline{PG1}$  is tied to  $\overline{MR}$ .

$\overline{EN1}$  and  $\overline{EN2}$  are initially high; therefore, both regulators are off, and  $\overline{PG1}$  (tied to  $\overline{MR}$ ) and  $\overline{PG2}$  are at logic low. Since  $\overline{MR}$  is at logic low,  $\overline{RESET}$  is also at logic low. When  $\overline{EN2}$  is taken to logic low,  $V_{OUT2}$  turns on. Later, when  $\overline{EN1}$  is taken to logic low,  $V_{OUT1}$  turns on. When  $V_{OUT2}$  reaches 95% of its regulated output voltage,  $\overline{PG2}$  goes to logic high. When  $V_{OUT1}$  reaches 95% of its regulated output voltage,  $\overline{PG1}$  goes to logic high. When  $V_{IN1}$  is greater than  $V_{UVLO}$  and  $\overline{MR}$  (tied to  $\overline{PG2}$ ) is at logic high,  $\overline{RESET}$  is pulled to logic high after a 120ms delay. When a fault on  $V_{OUT1}$  causes it to fall below 95% of its regulated output voltage,  $\overline{PG1}$  (tied to  $\overline{MR}$ ) goes to logic low. Since  $\overline{MR}$  is logic low,  $\overline{RESET}$  goes to logic low.  $V_{OUT2}$  is unaffected.

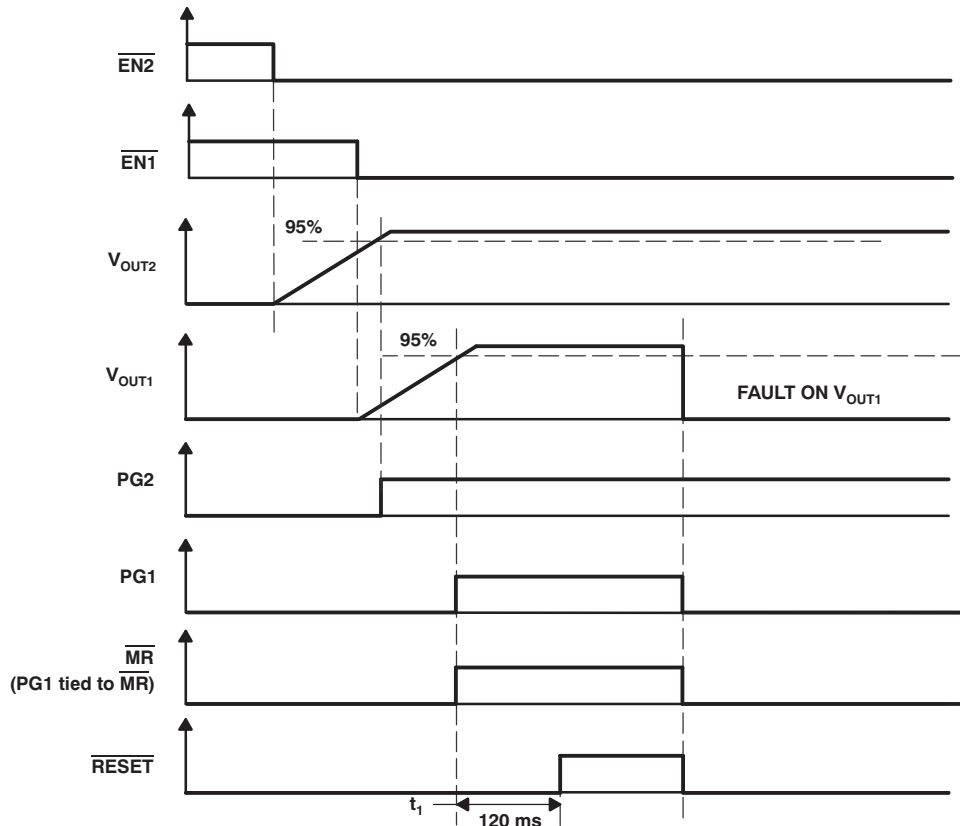
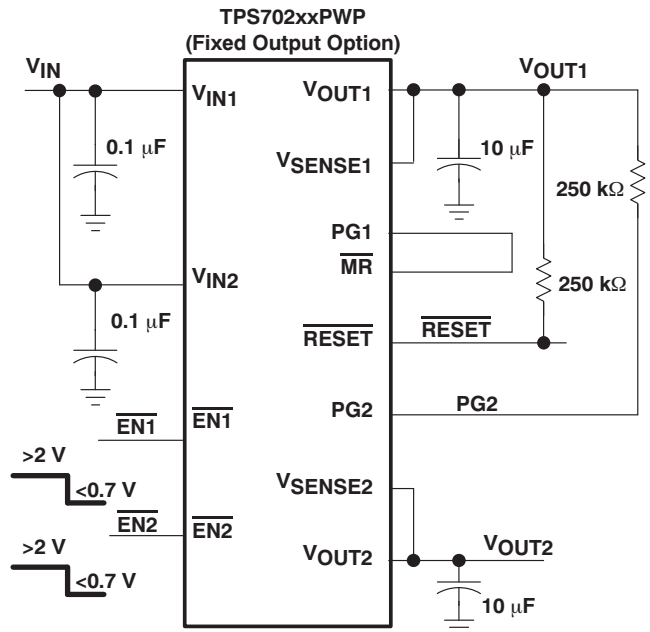

NOTES: A.  $t_1$ : Time at which  $V_{IN}$  is greater than  $V_{UVLO}$  and  $\overline{MR}$  is logic high.  
 B. The timing diagram is not drawn to scale.

**Figure 36. Timing When  $V_{OUT1}$  Faults Out**

## APPLICATION INFORMATION

### Input Capacitor

For a typical application, an input bypass capacitor (0.1 $\mu$ F to 1 $\mu$ F) is recommended. This capacitor filters any high-frequency noise generated in the line. For fast transient conditions where droop at the input of the LDO may occur because of high inrush current, it is recommended to place a larger capacitor at the input as well. The size of this capacitor depends on the output current and response time of the main power supply, as well as the distance to the  $V_I$  pins of the LDO.

### Output Capacitor

As with most LDO regulators, the TPS702xx requires an output capacitor connected between OUT and GND to stabilize the internal control loop. The minimum recommended capacitance values are 10 $\mu$ F ceramic capacitors with an ESR (equivalent series resistance) between 50m $\Omega$  and 2.5 $\Omega$  or 6.8 $\mu$ F tantalum capacitors with ESR between 250m $\Omega$  and 4 $\Omega$ . Solid tantalum electrolytic, aluminum electrolytic, and multilayer ceramic capacitors with capacitance values greater than 10 $\mu$ F are all suitable, provided they meet the requirements described above. Larger capacitors provide a wider range of stability and better load transient response. [Table 1](#) gives a partial listing of surface-mount capacitors suitable for use with the TPS702xx for fast transient response applications.

This information, along with the ESR graphs, is included to assist in selection of suitable capacitance for user applications. When necessary to achieve low height requirements along with high output current and/or high load capacitance, several higher ESR capacitors can be used in parallel to meet the guidelines above.

**Table 1. Partial Listing of TPS702xx-Compatible Surface-Mount Capacitors**

VALUE	MANUFACTURER	MAXIMUM ESR	MFR PART NO.
22 $\mu$ F	Kemet	345m $\Omega$	7495C226K0010AS
33 $\mu$ F	Sanyo	100m $\Omega$	10TPA33M
47 $\mu$ F	Sanyo	100m $\Omega$	6TPA47M
68 $\mu$ F	Sanyo	45m $\Omega$	10TPC68M

### ESR and Transient Response

LDOs typically require an external output capacitor for stability. In fast transient response applications, capacitors are used to support the load current while the LDO amplifier is responding. In most applications, one capacitor is used to support both functions.

Besides its capacitance, every capacitor also contains parasitic impedances. These parasitic impedances are resistive as well as inductive. The resistive impedance is called *equivalent series resistance* (ESR), and the inductive impedance is called *equivalent series inductance* (ESL). The equivalent schematic diagram of any capacitor can therefore be drawn as shown in [Figure 37](#).



**Figure 37. ESR and ESL**

In most cases one can neglect the effect of inductive impedance ESL. Therefore, the following application focuses mainly on the parasitic resistance ESR.

Figure 38 shows the output capacitor and its parasitic impedances in a typical LDO output stage.

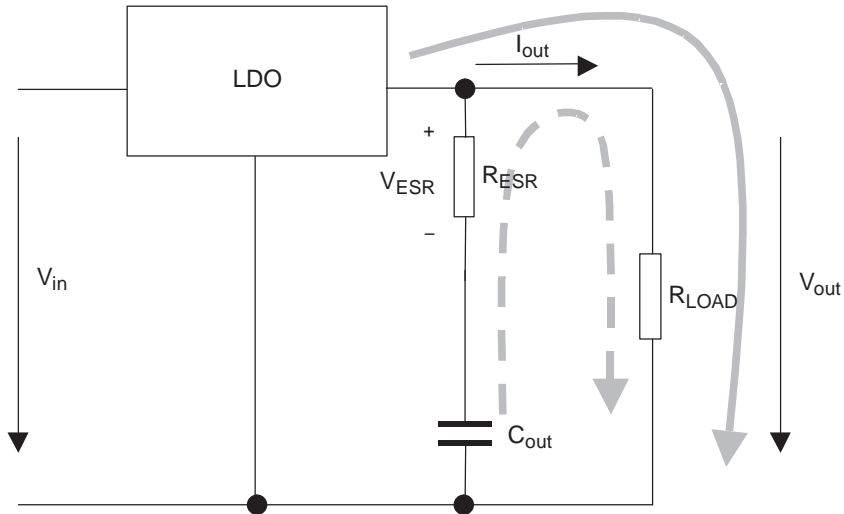
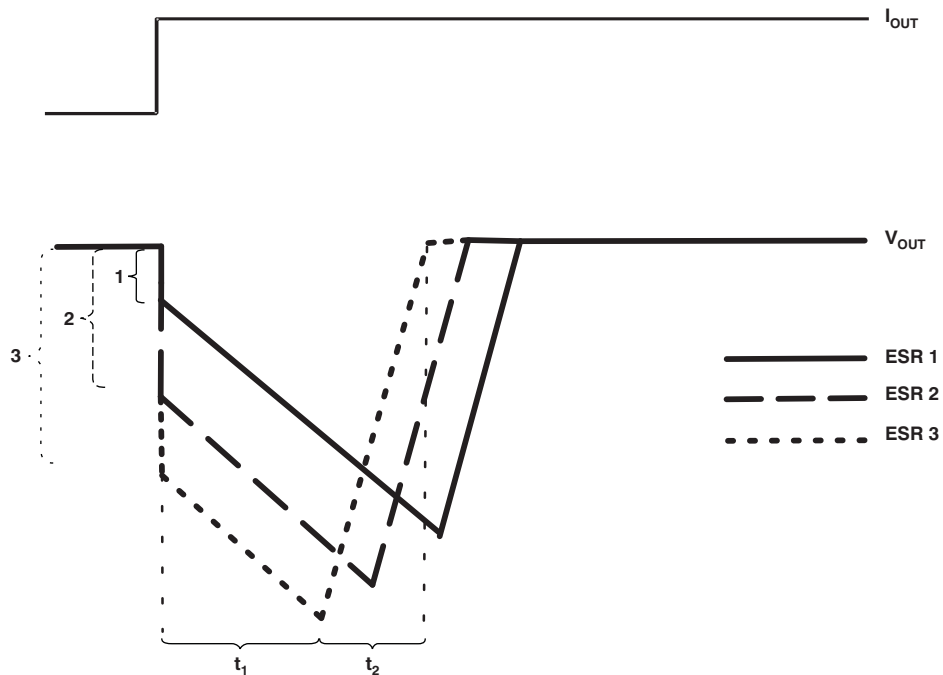

Figure 38. LDO Output Stage with Parasitic Resistances ESR

In steady state (dc state condition), the load current is supplied by the LDO (solid arrow) and the voltage across the capacitor is the same as the output voltage ( $V_{(CO)} = V_{OUT}$ ). This condition means no current is flowing into the  $C_{OUT}$  branch. If  $I_{OUT}$  suddenly increases (a transient condition), the following results occur:

- The LDO is not able to supply the sudden current need because of its response time ( $t_1$  in Figure 39). Therefore, capacitor  $C_{OUT}$  provides the current for the new load condition (dashed arrow).  $C_{OUT}$  now acts like a battery with an internal resistance, ESR. Depending on the current demand at the output, a voltage drop occurs at  $R_{ESR}$ . This voltage is shown as  $V_{ESR}$  in Figure 38.
- When  $C_{OUT}$  is conducting current to the load, initial voltage at the load will be  $V_{OUT} = V_{(CO)} - V_{ESR}$ . As a result of the discharge of  $C_{OUT}$ , the output voltage  $V_{OUT}$  drops continuously until the response time  $t_1$  of the LDO is reached and the LDO resumes supplying the load. From this point, the output voltage starts rising again until it reaches the regulated voltage. This period is shown as  $t_2$  in Figure 39.



**Figure 39. Correlation of Different ESRs and Their Influence on the Regulation of  $V_O$  at a Load Step from Low-to-High Output Current**

Figure 39 also shows the impact of different ESRs on the output voltage. The left brackets show different levels of ESRs where number 1 displays the lowest and number 3 displays the highest ESR.

From above, the following conclusions can be drawn:

- The higher the ESR, the larger the droop at the beginning of the load transient.
- The smaller the output capacitor, the faster the discharge time and the greater the voltage droop during the LDO response period.

### Conclusion

To minimize the transient output droop, capacitors must have a low ESR and be large enough to support the minimum output voltage requirement.

### Programming the TPS70202 Adjustable LDO Regulator

The output voltage of the TPS70202 adjustable regulators is programmed using external resistor dividers as shown in Figure 40.

Resistors R1 and R2 should be chosen for approximately a 50 $\mu$ A divider current. Lower value resistors can be used, but offer no inherent advantage and waste more power. Higher values should be avoided as leakage currents at the sense terminal increase the output voltage error. The recommended design procedure is to choose R2 = 30.1k $\Omega$  to set the divider current at approximately 50 $\mu$ A, and then calculate R1 using Equation 1:

$$R1 = \left( \frac{V_{OUT}}{V_{REF}} - 1 \right) \times R2 \quad (1)$$

where:

- $V_{REF}$  = 1.224V typ (the internal reference voltage)

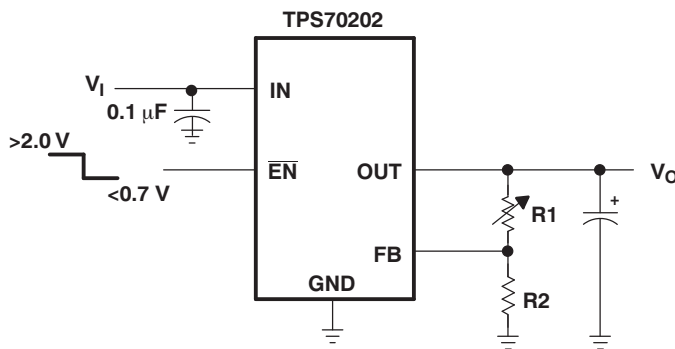

OUTPUT VOLTAGE  
 PROGRAMMING GUIDE

OUTPUT VOLTAGE	R1	R2	UNIT
2.5 V	31.6	30.1	kΩ
3.3 V	51.1	30.1	kΩ
3.6 V	59.0	30.1	kΩ

Figure 40. TPS70202 Adjustable LDO Regulator Programming

## Regulator Protection

Both TPS702xx PMOS-pass transistors have built-in back diodes that conduct reverse currents when the input voltage drops below the output voltage (for example, during power-down). Current is conducted from the output to the input and is not internally limited. When extended reverse voltage is anticipated, external limiting may be appropriate.

The TPS702xx also features internal current limiting and thermal protection. During normal operation, the TPS702xx regulator 1 limits output current to approximately 1.6A (typ) and regulator 2 limits output current to approximately 750mA (typ). When current limiting engages, the output voltage scales back linearly until the overcurrent condition ends. While current limiting is designed to prevent gross device failure, care should be taken not to exceed the power dissipation ratings of the package. If the temperature of the device exceeds +150°C (typ), thermal-protection circuitry shuts it down. Once the device has cooled below +130°C (typ), regulator operation resumes.

## Power Dissipation and Junction Temperature

Specified regulator operation is assured to a junction temperature of +125°C; the maximum junction temperature should be restricted to +125°C under normal operating conditions. This restriction limits the power dissipation the regulator can handle in any given application. To ensure the junction temperature is within acceptable limits, calculate the maximum allowable dissipation,  $P_{D(max)}$ , and the actual dissipation,  $P_D$ , which must be less than or equal to  $P_{D(max)}$ .

The maximum-power-dissipation limit is determined using [Equation 2](#):

$$P_{D(max)} = \frac{T_{Jmax} - T_A}{R_{\theta JA}} \quad (2)$$

where:

- $T_{Jmax}$  is the maximum allowable junction temperature
- $R_{\theta JA}$  is the thermal resistance junction-to-ambient for the package; that is, 32.6°C/W for the 20-terminal PWP with no airflow
- $T_A$  is the ambient temperature

The regulator dissipation is calculated using [Equation 3](#):

$$P_D = (V_I - V_O) \times I_O \quad (3)$$

Power dissipation resulting from quiescent current is negligible. Excessive power dissipation triggers the thermal protection circuit.

## REVISION HISTORY

NOTE: Page numbers for previous revisions may differ from page numbers in the current version.

Changes from Revision D (December, 2007) to Revision E	Page
• Corrected typo in <i>output current limit</i> specification units .....	5
• Deleted <i>falling edge delay</i> specification .....	6
• Updated <i>Fixed Voltage Version</i> block diagram .....	7
• Updated <i>Adjustable Voltage Version</i> block diagram .....	8

**PACKAGING INFORMATION**

Orderable Device	Status <sup>(1)</sup>	Package Type	Package Drawing	Pins	Package Qty	Eco Plan <sup>(2)</sup>	Lead/Ball Finish	MSL Peak Temp <sup>(3)</sup>
TPS70202PWP	ACTIVE	HTSSOP	PWP	20	70	Green (RoHS & no Sb/Br)	CU NIPDAU	Level-2-260C-1 YEAR
TPS70202PWPG4	ACTIVE	HTSSOP	PWP	20	70	Green (RoHS & no Sb/Br)	CU NIPDAU	Level-2-260C-1 YEAR
TPS70202PWPR	ACTIVE	HTSSOP	PWP	20	2000	Green (RoHS & no Sb/Br)	CU NIPDAU	Level-2-260C-1 YEAR
TPS70202PWPRG4	ACTIVE	HTSSOP	PWP	20	2000	Green (RoHS & no Sb/Br)	CU NIPDAU	Level-2-260C-1 YEAR
TPS70245PWP	ACTIVE	HTSSOP	PWP	20	70	Green (RoHS & no Sb/Br)	CU NIPDAU	Level-2-260C-1 YEAR
TPS70245PWPG4	ACTIVE	HTSSOP	PWP	20	70	Green (RoHS & no Sb/Br)	CU NIPDAU	Level-2-260C-1 YEAR
TPS70245PWPR	ACTIVE	HTSSOP	PWP	20	2000	Green (RoHS & no Sb/Br)	CU NIPDAU	Level-2-260C-1 YEAR
TPS70245PWPRG4	ACTIVE	HTSSOP	PWP	20	2000	Green (RoHS & no Sb/Br)	CU NIPDAU	Level-2-260C-1 YEAR
TPS70248PWP	ACTIVE	HTSSOP	PWP	20	70	Green (RoHS & no Sb/Br)	CU NIPDAU	Level-2-260C-1 YEAR
TPS70248PWPG4	ACTIVE	HTSSOP	PWP	20	70	Green (RoHS & no Sb/Br)	CU NIPDAU	Level-2-260C-1 YEAR
TPS70248PWPR	ACTIVE	HTSSOP	PWP	20	2000	Green (RoHS & no Sb/Br)	CU NIPDAU	Level-2-260C-1 YEAR
TPS70248PWPRG4	ACTIVE	HTSSOP	PWP	20	2000	Green (RoHS & no Sb/Br)	CU NIPDAU	Level-2-260C-1 YEAR
TPS70251PWP	ACTIVE	HTSSOP	PWP	20	70	Green (RoHS & no Sb/Br)	CU NIPDAU	Level-2-260C-1 YEAR
TPS70251PWPG4	ACTIVE	HTSSOP	PWP	20	70	Green (RoHS & no Sb/Br)	CU NIPDAU	Level-2-260C-1 YEAR
TPS70251PWPR	ACTIVE	HTSSOP	PWP	20	2000	Green (RoHS & no Sb/Br)	CU NIPDAU	Level-2-260C-1 YEAR
TPS70251PWPRG4	ACTIVE	HTSSOP	PWP	20	2000	Green (RoHS & no Sb/Br)	CU NIPDAU	Level-2-260C-1 YEAR
TPS70258PWP	ACTIVE	HTSSOP	PWP	20	70	Green (RoHS & no Sb/Br)	CU NIPDAU	Level-2-260C-1 YEAR
TPS70258PWPG4	ACTIVE	HTSSOP	PWP	20	70	Green (RoHS & no Sb/Br)	CU NIPDAU	Level-2-260C-1 YEAR
TPS70258PWPR	ACTIVE	HTSSOP	PWP	20	2000	Green (RoHS & no Sb/Br)	CU NIPDAU	Level-2-260C-1 YEAR
TPS70258PWPRG4	ACTIVE	HTSSOP	PWP	20	2000	Green (RoHS & no Sb/Br)	CU NIPDAU	Level-2-260C-1 YEAR

<sup>(1)</sup> The marketing status values are defined as follows:

**ACTIVE:** Product device recommended for new designs.

**LIFEBUY:** TI has announced that the device will be discontinued, and a lifetime-buy period is in effect.

**NRND:** Not recommended for new designs. Device is in production to support existing customers, but TI does not recommend using this part in a new design.

**PREVIEW:** Device has been announced but is not in production. Samples may or may not be available.

**OBSOLETE:** TI has discontinued the production of the device.

<sup>(2)</sup> Eco Plan - The planned eco-friendly classification: Pb-Free (RoHS), Pb-Free (RoHS Exempt), or Green (RoHS & no Sb/Br) - please check <http://www.ti.com/productcontent> for the latest availability information and additional product content details.

**TBD:** The Pb-Free/Green conversion plan has not been defined.

**Pb-Free (RoHS):** TI's terms "Lead-Free" or "Pb-Free" mean semiconductor products that are compatible with the current RoHS requirements for all 6 substances, including the requirement that lead not exceed 0.1% by weight in homogeneous materials. Where designed to be soldered at high temperatures, TI Pb-Free products are suitable for use in specified lead-free processes.

**Pb-Free (RoHS Exempt):** This component has a RoHS exemption for either 1) lead-based flip-chip solder bumps used between the die and package, or 2) lead-based die adhesive used between the die and leadframe. The component is otherwise considered Pb-Free (RoHS compatible) as defined above.

**Green (RoHS & no Sb/Br):** TI defines "Green" to mean Pb-Free (RoHS compatible), and free of Bromine (Br) and Antimony (Sb) based flame retardants (Br or Sb do not exceed 0.1% by weight in homogeneous material)

<sup>(3)</sup> MSL, Peak Temp. -- The Moisture Sensitivity Level rating according to the JEDEC industry standard classifications, and peak solder temperature.

**Important Information and Disclaimer:**The information provided on this page represents TI's knowledge and belief as of the date that it is provided. TI bases its knowledge and belief on information provided by third parties, and makes no representation or warranty as to the accuracy of such information. Efforts are underway to better integrate information from third parties. TI has taken and continues to take reasonable steps to provide representative and accurate information but may not have conducted destructive testing or chemical analysis on incoming materials and chemicals. TI and TI suppliers consider certain information to be proprietary, and thus CAS numbers and other limited information may not be available for release.

In no event shall TI's liability arising out of such information exceed the total purchase price of the TI part(s) at issue in this document sold by TI to Customer on an annual basis.

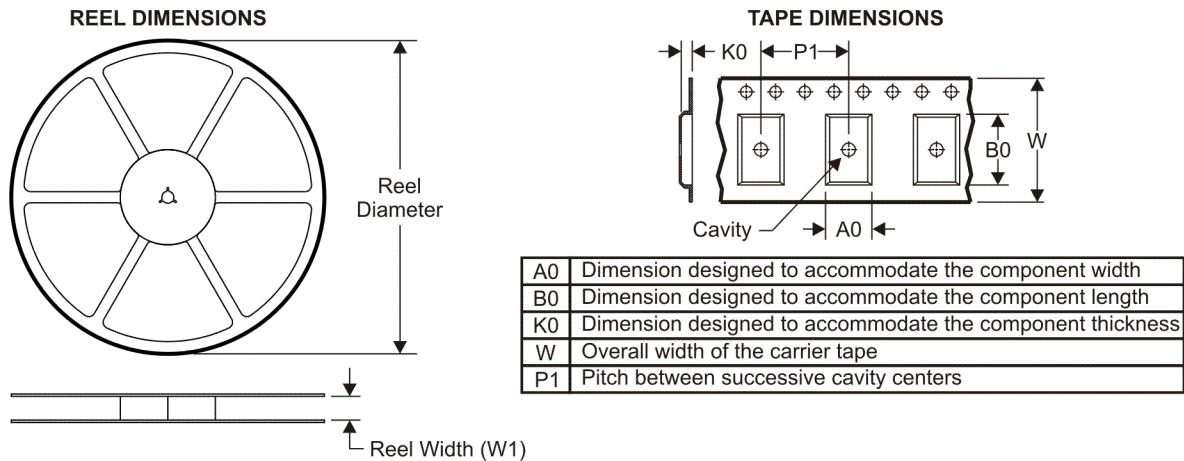
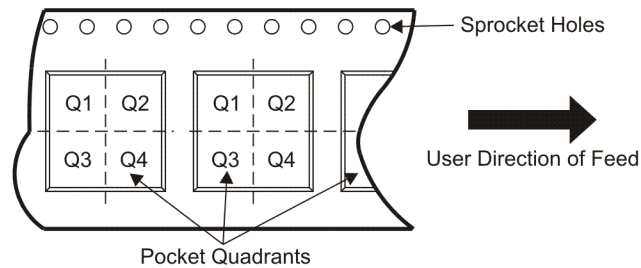
**TAPE AND REEL INFORMATION**

**QUADRANT ASSIGNMENTS FOR PIN 1 ORIENTATION IN TAPE**

\*All dimensions are nominal

Device	Package Type	Package Drawing	Pins	SPQ	Reel Diameter (mm)	Reel Width W1 (mm)	A0 (mm)	B0 (mm)	K0 (mm)	P1 (mm)	W (mm)	Pin1 Quadrant
TPS70202PWPR	HTSSOP	PWP	20	2000	330.0	16.4	6.95	7.1	1.6	8.0	16.0	Q1
TPS70245PWPR	HTSSOP	PWP	20	2000	330.0	16.4	6.95	7.1	1.6	8.0	16.0	Q1
TPS70248PWPR	HTSSOP	PWP	20	2000	330.0	16.4	6.95	7.1	1.6	8.0	16.0	Q1
TPS70251PWPR	HTSSOP	PWP	20	2000	330.0	16.4	6.95	7.1	1.6	8.0	16.0	Q1
TPS70258PWPR	HTSSOP	PWP	20	2000	330.0	16.4	6.95	7.1	1.6	8.0	16.0	Q1

**TAPE AND REEL BOX DIMENSIONS**

\*All dimensions are nominal

Device	Package Type	Package Drawing	Pins	SPQ	Length (mm)	Width (mm)	Height (mm)
TPS70202PWPR	HTSSOP	PWP	20	2000	346.0	346.0	33.0
TPS70245PWPR	HTSSOP	PWP	20	2000	346.0	346.0	33.0
TPS70248PWPR	HTSSOP	PWP	20	2000	346.0	346.0	33.0
TPS70251PWPR	HTSSOP	PWP	20	2000	346.0	346.0	33.0
TPS70258PWPR	HTSSOP	PWP	20	2000	346.0	346.0	33.0

PWP (R-PDSO-G20)

PowerPAD™ PLASTIC SMALL OUTLINE

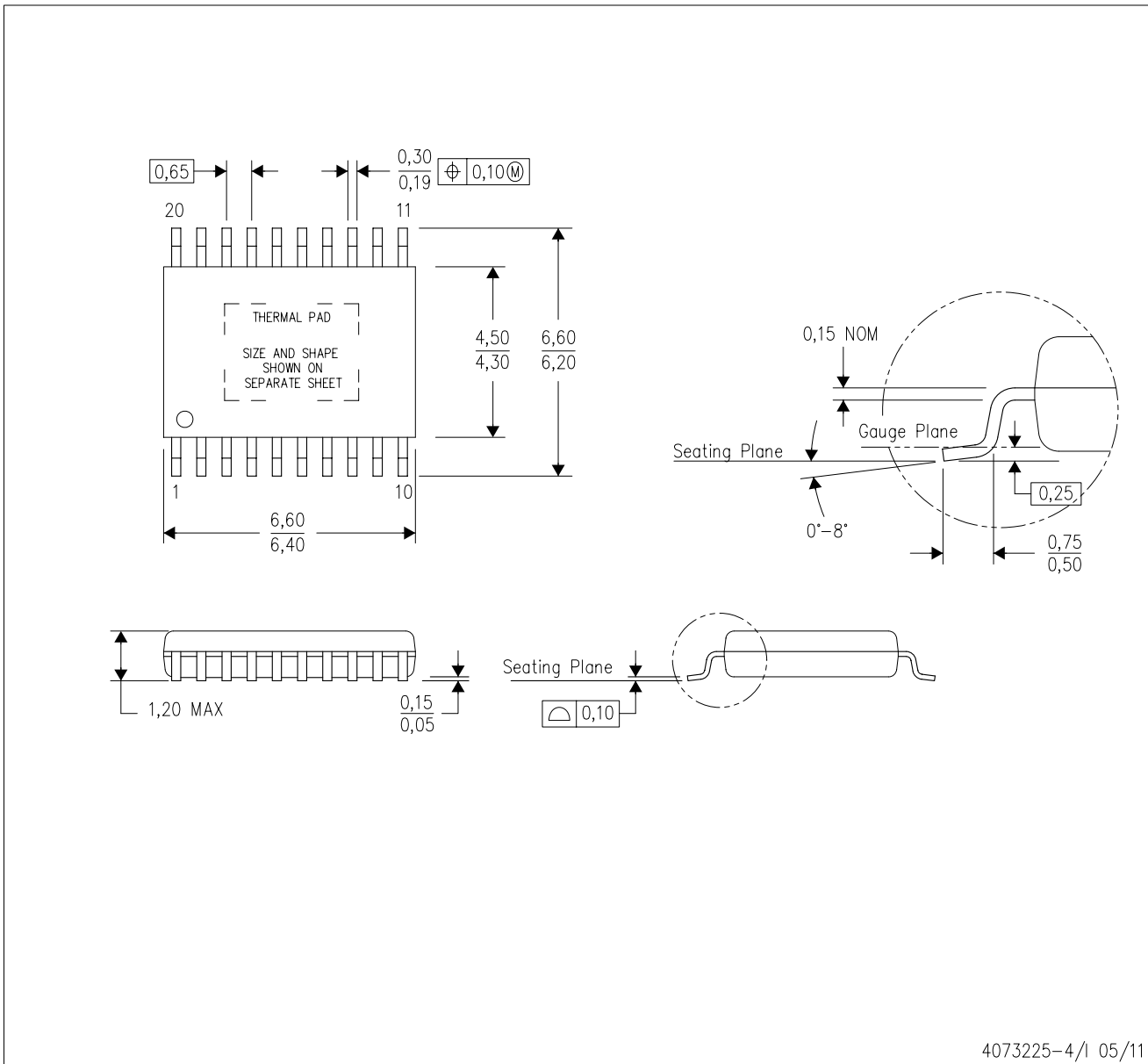

4073225-4/1 05/11

- NOTES:
- All linear dimensions are in millimeters.
  - This drawing is subject to change without notice.
  - Body dimensions do not include mold flash or protrusions. Mold flash and protrusion shall not exceed 0.15 per side.
  - This package is designed to be soldered to a thermal pad on the board. Refer to Technical Brief, PowerPad Thermally Enhanced Package, Texas Instruments Literature No. SLMA002 for information regarding recommended board layout. This document is available at [www.ti.com](http://www.ti.com) <<http://www.ti.com>>.
  - See the additional figure in the Product Data Sheet for details regarding the exposed thermal pad features and dimensions.
  - Falls within JEDEC MO-153

PowerPAD is a trademark of Texas Instruments.

## THERMAL PAD MECHANICAL DATA

### PWP (R-PDSO-G20) PowerPAD™ SMALL PLASTIC OUTLINE

#### THERMAL INFORMATION

This PowerPAD™ package incorporates an exposed thermal pad that is designed to be attached to a printed circuit board (PCB). The thermal pad must be soldered directly to the PCB. After soldering, the PCB can be used as a heatsink. In addition, through the use of thermal vias, the thermal pad can be attached directly to the appropriate copper plane shown in the electrical schematic for the device, or alternatively, can be attached to a special heatsink structure designed into the PCB. This design optimizes the heat transfer from the integrated circuit (IC).

For additional information on the PowerPAD package and how to take advantage of its heat dissipating abilities, refer to Technical Brief, PowerPAD Thermally Enhanced Package, Texas Instruments Literature No. SLMA002 and Application Brief, PowerPAD Made Easy, Texas Instruments Literature No. SLMA004. Both documents are available at [www.ti.com](http://www.ti.com).

The exposed thermal pad dimensions for this package are shown in the following illustration.

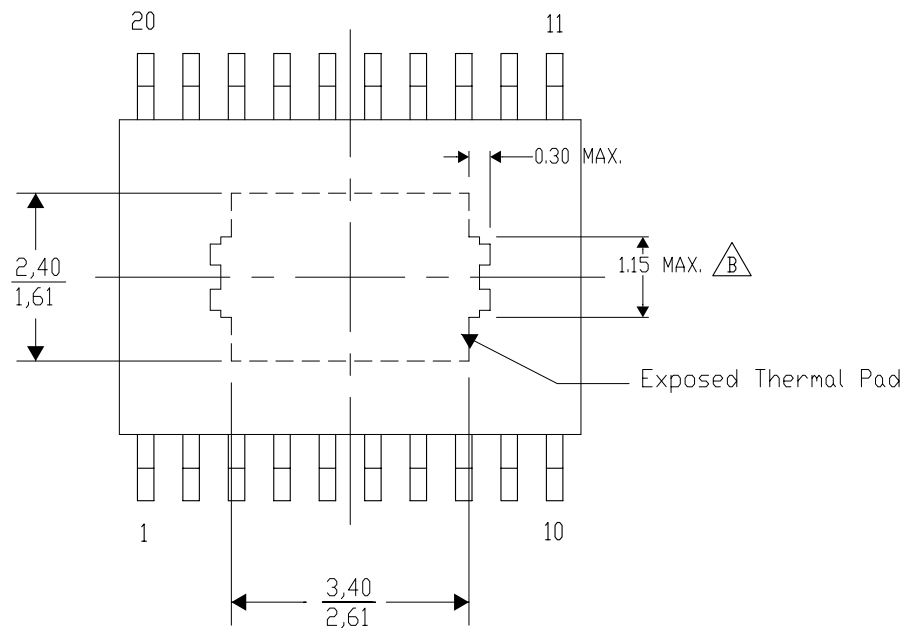

Top View

Exposed Thermal Pad Dimensions

4206332-8/W 05/11

NOTE: A. All linear dimensions are in millimeters

 Exposed tie strap features may not be present.

PowerPAD is a trademark of Texas Instruments

PWP (R-PDSO-G20)

PowerPAD™ PLASTIC SMALL OUTLINE

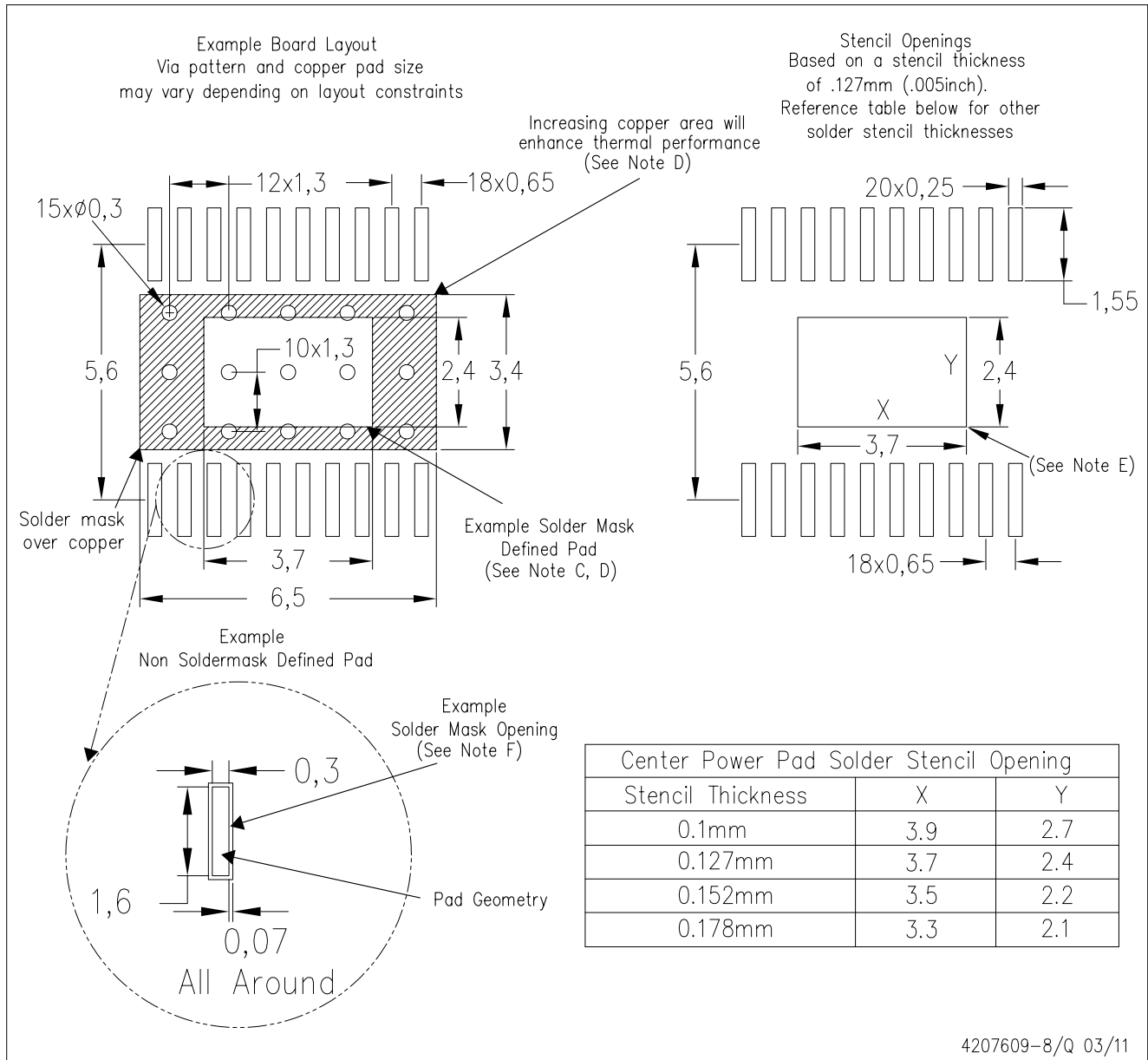

- NOTES:
- A. All linear dimensions are in millimeters.
  - B. This drawing is subject to change without notice.
  - C. Customers should place a note on the circuit board fabrication drawing not to alter the center solder mask defined pad.
  - D. This package is designed to be soldered to a thermal pad on the board. Refer to Technical Brief, PowerPad Thermally Enhanced Package, Texas Instruments Literature No. SLMA002, SLMA004, and also the Product Data Sheets for specific thermal information, via requirements, and recommended board layout. These documents are available at [www.ti.com](http://www.ti.com) <<http://www.ti.com>>. Publication IPC-7351 is recommended for alternate designs.
  - E. Laser cutting apertures with trapezoidal walls and also rounding corners will offer better paste release. Customers should contact their board assembly site for stencil design recommendations. Example stencil design based on a 50% volumetric metal load solder paste. Refer to IPC-7525 for other stencil recommendations.
  - F. Customers should contact their board fabrication site for solder mask tolerances between and around signal pads.

PowerPAD is a trademark of Texas Instruments.

## IMPORTANT NOTICE

Texas Instruments Incorporated and its subsidiaries (TI) reserve the right to make corrections, modifications, enhancements, improvements, and other changes to its products and services at any time and to discontinue any product or service without notice. Customers should obtain the latest relevant information before placing orders and should verify that such information is current and complete. All products are sold subject to TI's terms and conditions of sale supplied at the time of order acknowledgment.

TI warrants performance of its hardware products to the specifications applicable at the time of sale in accordance with TI's standard warranty. Testing and other quality control techniques are used to the extent TI deems necessary to support this warranty. Except where mandated by government requirements, testing of all parameters of each product is not necessarily performed.

TI assumes no liability for applications assistance or customer product design. Customers are responsible for their products and applications using TI components. To minimize the risks associated with customer products and applications, customers should provide adequate design and operating safeguards.

TI does not warrant or represent that any license, either express or implied, is granted under any TI patent right, copyright, mask work right, or other TI intellectual property right relating to any combination, machine, or process in which TI products or services are used. Information published by TI regarding third-party products or services does not constitute a license from TI to use such products or services or a warranty or endorsement thereof. Use of such information may require a license from a third party under the patents or other intellectual property of the third party, or a license from TI under the patents or other intellectual property of TI.

Reproduction of TI information in TI data books or data sheets is permissible only if reproduction is without alteration and is accompanied by all associated warranties, conditions, limitations, and notices. Reproduction of this information with alteration is an unfair and deceptive business practice. TI is not responsible or liable for such altered documentation. Information of third parties may be subject to additional restrictions.

Resale of TI products or services with statements different from or beyond the parameters stated by TI for that product or service voids all express and any implied warranties for the associated TI product or service and is an unfair and deceptive business practice. TI is not responsible or liable for any such statements.

TI products are not authorized for use in safety-critical applications (such as life support) where a failure of the TI product would reasonably be expected to cause severe personal injury or death, unless officers of the parties have executed an agreement specifically governing such use. Buyers represent that they have all necessary expertise in the safety and regulatory ramifications of their applications, and acknowledge and agree that they are solely responsible for all legal, regulatory and safety-related requirements concerning their products and any use of TI products in such safety-critical applications, notwithstanding any applications-related information or support that may be provided by TI. Further, Buyers must fully indemnify TI and its representatives against any damages arising out of the use of TI products in such safety-critical applications.

TI products are neither designed nor intended for use in military/aerospace applications or environments unless the TI products are specifically designated by TI as military-grade or "enhanced plastic." Only products designated by TI as military-grade meet military specifications. Buyers acknowledge and agree that any such use of TI products which TI has not designated as military-grade is solely at the Buyer's risk, and that they are solely responsible for compliance with all legal and regulatory requirements in connection with such use.

TI products are neither designed nor intended for use in automotive applications or environments unless the specific TI products are designated by TI as compliant with ISO/TS 16949 requirements. Buyers acknowledge and agree that, if they use any non-designated products in automotive applications, TI will not be responsible for any failure to meet such requirements.

Following are URLs where you can obtain information on other Texas Instruments products and application solutions:

### Products

Audio	<a href="http://www.ti.com/audio">www.ti.com/audio</a>
Amplifiers	<a href="http://amplifier.ti.com">amplifier.ti.com</a>
Data Converters	<a href="http://dataconverter.ti.com">dataconverter.ti.com</a>
DLP® Products	<a href="http://www.dlp.com">www.dlp.com</a>
DSP	<a href="http://dsp.ti.com">dsp.ti.com</a>
Clocks and Timers	<a href="http://www.ti.com/clocks">www.ti.com/clocks</a>
Interface	<a href="http://interface.ti.com">interface.ti.com</a>
Logic	<a href="http://logic.ti.com">logic.ti.com</a>
Power Mgmt	<a href="http://power.ti.com">power.ti.com</a>
Microcontrollers	<a href="http://microcontroller.ti.com">microcontroller.ti.com</a>
RFID	<a href="http://www.ti-rfid.com">www.ti-rfid.com</a>
RF/IF and ZigBee® Solutions	<a href="http://www.ti.com/lprf">www.ti.com/lprf</a>

### Applications

Communications and Telecom	<a href="http://www.ti.com/communications">www.ti.com/communications</a>
Computers and Peripherals	<a href="http://www.ti.com/computers">www.ti.com/computers</a>
Consumer Electronics	<a href="http://www.ti.com/consumer-apps">www.ti.com/consumer-apps</a>
Energy and Lighting	<a href="http://www.ti.com/energy">www.ti.com/energy</a>
Industrial	<a href="http://www.ti.com/industrial">www.ti.com/industrial</a>
Medical	<a href="http://www.ti.com/medical">www.ti.com/medical</a>
Security	<a href="http://www.ti.com/security">www.ti.com/security</a>
Space, Avionics and Defense	<a href="http://www.ti.com/space-avionics-defense">www.ti.com/space-avionics-defense</a>
Transportation and Automotive	<a href="http://www.ti.com/automotive">www.ti.com/automotive</a>
Video and Imaging	<a href="http://www.ti.com/video">www.ti.com/video</a>
Wireless	<a href="http://www.ti.com/wireless-apps">www.ti.com/wireless-apps</a>

TI E2E Community Home Page

[e2e.ti.com](http://e2e.ti.com)

Mailing Address: Texas Instruments, Post Office Box 655303, Dallas, Texas 75265  
Copyright © 2011, Texas Instruments Incorporated